

# 2023

## Manual ZRS2600

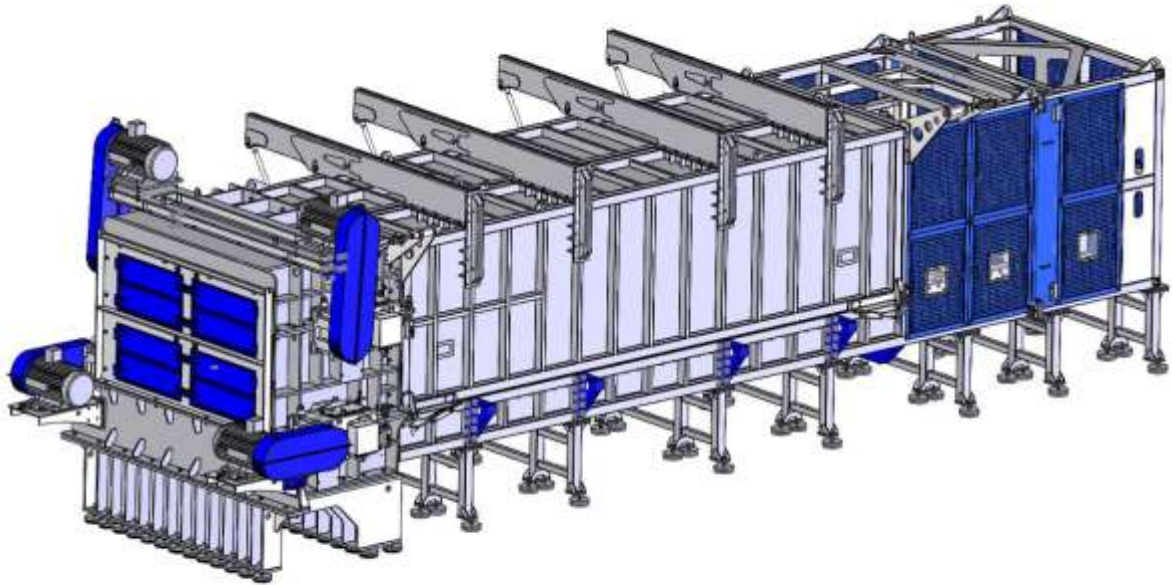

Zerma America

9120 Centerlinks Commerce Drive  
Unit 4  
Fort Myers, FL 33912

Phone: 293-219-1500  
[www.zerma-America.com](http://www.zerma-America.com)



**ZERMA**

## Table of Contents

|             |   |           |
|-------------|---|-----------|
| <b>1</b>    | <b>Information on this instruction manual</b>           | <b>6</b>  |
| <b>2</b>    | <b>Technical data</b>                                   | <b>7</b>  |
| <b>2.1</b>  | <b>ZRS 2600</b>   | <b>7</b>  |
| <b>3</b>    | <b>General Information</b>                              | <b>8</b>  |
| <b>3.1</b>  | <b>Copyright</b>  | <b>8</b>  |
| <b>3.2</b>  | <b>Application</b>                                      | <b>8</b>  |
| <b>3.3</b>  | <b>Safety</b>   | <b>8</b>  |
| <b>3.4</b>  | <b>Inspection of goods</b>                              | <b>8</b>  |
| <b>4</b>    | <b>General safety advice</b>                            | <b>9</b>  |
| <b>4.1</b>  | <b>Safe operation of the machine</b>                    | <b>9</b>  |
| <b>4.2</b>  | <b>Use in accordance with the regulations</b>           | <b>10</b> |
| <b>4.3</b>  | <b>Liability and Responsibility</b>                     | <b>12</b> |
| <b>4.4</b>  | <b>Structural changes, spare parts, accessories</b>     | <b>13</b> |
| <b>4.5</b>  | <b>Operation manuals from other manufacturers</b>       | <b>13</b> |
| <b>4.6</b>  | <b>Noise levels and noise control measures</b>          | <b>14</b> |
| <b>4.7</b>  | <b>Work stations</b>                                    | <b>14</b> |
| <b>4.8</b>  | <b>Remaining risks</b>                                  | <b>15</b> |
| 4.8.1       | Mechanical dangers                                      | 15        |
| 4.8.2       | Electrical dangers                                      | 16        |
| 4.8.3       | Dangers caused by the control system                    | 17        |
| 4.8.4       | Thermal dangers   | 17        |
| 4.8.5       | Dangers caused by noise                                 | 17        |
| 4.8.6       | Dangers caused by vibration                             | 17        |
| 4.8.7       | Dangers caused by materials and substances              | 18        |
| 4.8.8       | Danger caused by manipulation of the protective devices | 18        |
| <b>4.9</b>  | <b>Protective devices</b>                               | <b>19</b> |
| 4.9.1       | Safety device for housing flap                          | 19        |
| 4.9.2       | "V"-belts and pusher protector                          | 20        |
| 4.9.3       | Safety Light grid                                       | 21        |
| 4.9.4       | Hopper safety lock                                      | 22        |
| 4.9.5       | Safety markings   | 22        |
| <b>4.10</b> | <b>Authorized persons</b>                               | <b>23</b> |
| <b>4.11</b> | <b>Personal protective gear</b>                         | <b>24</b> |
| <b>4.12</b> | <b>Safety measures at the application site</b>          | <b>25</b> |
| <b>4.13</b> | <b>Fire fighting agents</b>                             | <b>25</b> |
| <b>4.14</b> | <b>Cleaning agents</b>                                  | <b>25</b> |
| <b>4.15</b> | <b>Conduct in case of an emergency</b>                  | <b>25</b> |
| <b>4.16</b> | <b>Classification of specific safety advice</b>         | <b>26</b> |



|            |  |                              |
|------------|--|------------------------------|
| <b>5</b>   | <b>Description of the machine</b>                          | <b>27</b>                    |
| <b>5.1</b> | <b>Functional description</b>                              | <b>27</b>                    |
| 5.1.1      | Mechanical section   | 27                           |
| 5.1.2      | Control  | 28                           |
| <b>5.2</b> | <b>Grinding material in feed</b>                           | <b>29</b>                    |
| 5.2.1      | Feeding trough for side feed                               | 29                           |
| <b>5.3</b> | <b>Machine</b>   | Error! Bookmark not defined. |
| <b>5.4</b> | <b>Drive</b>   | <b>32</b>                    |
| <b>5.5</b> | <b>Rotor and knives</b>                                    | <b>33</b>                    |
| <b>5.6</b> | <b>Pre-breaker for thin-walled pipe/profile (optional)</b> | <b>34</b>                    |
| <b>5.7</b> | <b>Discharge of grinding material</b>                      | <b>34</b>                    |
| <b>5.8</b> | <b>Hydraulic pusher</b>                                    | <b>35</b>                    |
| <b>5.9</b> | <b>Control and operator panel</b>                          | <b>37</b>                    |
| <b>6</b>   | <b>Initial startup</b>                                     | <b>38</b>                    |
| <b>6.1</b> | <b>General Advice</b>                                      | <b>38</b>                    |
| <b>6.2</b> | <b>Requirements at the application site</b>                | <b>39</b>                    |
| <b>6.3</b> | <b>Unloading and installing the machine</b>                | <b>40</b>                    |
| <b>6.4</b> | <b>Electrical connection</b>                               | <b>41</b>                    |
| <b>6.5</b> | <b>Machine check prior to initial start-up</b>             | <b>43</b>                    |
| <b>7</b>   | <b>Operation</b>   | <b>44</b>                    |
| <b>7.1</b> | <b>Machine checks before switching on the machine</b>      | <b>44</b>                    |
| <b>7.2</b> | <b>Switch on machine</b>                                   | <b>44</b>                    |
| <b>7.3</b> | <b>Switch off machine</b>                                  | <b>45</b>                    |
| <b>7.4</b> | <b>Manual in feed of grinding material</b>                 | <b>45</b>                    |
| <b>8</b>   | <b>Maintenance</b>   | <b>46</b>                    |
| <b>8.1</b> | <b>Safety advice</b>                                       | <b>46</b>                    |
| <b>8.2</b> | <b>Maintenance plan</b>                                    | <b>47</b>                    |
| <b>8.3</b> | <b>Checking the protective devices</b>                     | <b>48</b>                    |
| <b>8.4</b> | <b>Cleaning the machine</b>                                | <b>49</b>                    |
| <b>8.5</b> | <b>Replacing the gear box</b>                              | <b>50</b>                    |
| <b>8.6</b> | <b>Replacing the rotor</b>                                 | <b>50</b>                    |
| <b>8.7</b> | <b>Replacing the main bearings</b>                         | <b>50</b>                    |
| <b>8.8</b> | <b>Lubricating the main bearings</b>                       | <b>51</b>                    |
| 8.8.1      | Lubrication intervals:                                     | 51                           |
| 8.8.2      | Check lubricant quality                                    | 51                           |
| 8.8.3      | Replacing or refilling lubricant                           | 51                           |
| 8.8.4      | List of lubricants   | 53                           |



|             |   |           |
|-------------|---|-----------|
| <b>8.9</b>  | <b>Mounting and dismounting TAPER-LOCK tensioning element</b> | <b>54</b> |
| 8.9.1       | Table for the tightening torque of the screws                 | 54        |
| 8.9.2       | Mounting the TAPER-LOCK tensioning element                    | 55        |
| 8.9.3       | Dismounting the TAPER-LOCK tensioning element                 | 55        |
| <b>8.10</b> | <b>Work on the "V"-belts</b>                                  | <b>56</b> |
| 8.10.1      | Checking the tension force of the "V"-belt                    | 56        |
| 8.10.2      | Retensioning and relaxing the "V"-belt                        | 57        |
| 8.10.3      | Checking "V"-belt condition, replacing "V"-belt               | 57        |
| <b>8.11</b> | <b>Working on the cutting knives</b>                          | <b>58</b> |
| 8.11.1      | Replacing and checking the cutting knife mountings            | 58        |
| 8.11.2      | Checking the condition of the cutting knives                  | 59        |
| 8.11.3      | Dismounting the rotor knives                                  | 60        |
| 8.11.4      | Dismounting the rotor knife holders                           | 61        |
| 8.11.5      | Dismounting the stator knives                                 | 63        |
| 8.11.6      | Mounting the rotor knife holders                              | 64        |
| 8.11.7      | Mounting the rotor knives                                     | 65        |
| 8.11.8      | Mounting and adjusting of the stator knives                   | 66        |
| 8.11.9      | Sharpening cutting knives                                     | 68        |
| 8.11.10     | Transporting and storing the cutting knives                   | 69        |
| <b>9</b>    | <b>Troubleshooting</b>  | <b>70</b> |
| 9.1         | Machine blocks or switches itself off                         | 70        |
| 9.2         | Rotor does not grip bulky material                            | 70        |
| 9.3         | Overheating of the grinding material                          | 70        |
| 9.4         | Unusual vibrations  | 70        |
| 9.5         | Extreme cutter wear   | 71        |
| 9.6         | Bearings too hot  | 71        |
| 9.7         | Cutting gap alters during operation                           | 71        |
| 9.8         | Shredder does not start                                       | 71        |
| 9.9         | Shredder blocks when under load                               | 71        |
| <b>10</b>   | <b>Storage, disposal, transportation</b>                      | <b>72</b> |
| 10.1        | Storage   | 72        |
| 10.2        | Disposal  | 72        |
| 10.3        | Transportation  | 72        |
| <b>11</b>   | <b>Hydraulic MAINTENANCE</b>                                  | <b>73</b> |
| 11.1        | Hydraulic set up  | 75        |
| 11.2        | Trouble shooting  | 76        |
| <b>12</b>   | <b>Customer service and spare parts orders</b>                | <b>77</b> |
| <b>13</b>   | <b>Spare Parts</b>  | <b>78</b> |
| <b>14</b>   | <b>Hydraulic Unit SHC-412 F ZRS1000-2000</b>                  | <b>79</b> |
| 14.1        | Hydraulic Diagram   | 79        |
| 14.2        | Spare parts list hydraulic unit                               | 80        |
| 14.3        | Hydraulic pump  | 81        |

**PART A: Basic machine  
Shredder  
ZRS2600**



---

|           |  |           |
|-----------|--|-----------|
| <b>15</b> | <b>CIARIFICATION FOR PERSONal TRAINING</b> | <b>82</b> |
| <b>16</b> | <b>Electrical Connection</b>               | <b>83</b> |
| <b>17</b> | <b>DIMENSIONS OF STANDARD MACHINE</b>      | <b>84</b> |
| <b>18</b> | <b>ADDITION</b>                            | <b>85</b> |



## **1 INFORMATION ON THIS INSTRUCTION MANUAL**

Author: ZERMA

No part of this operation manual may be reproduced, distributed or used in any shape or form, stored in a data processing system or translated into another language without written permission.

This operation manual serves to help you to get to know your machine and how to make use of its application possibilities in accordance with the regulations.

The operation manual contains important information on how to operate the machine safely, correctly and economically. Following this advice will help you to avoid danger, minimize repair costs and down times and to increase the reliability and durability of the machine.

Before you begin to work on and with the machine, please read the operation manual thoroughly. Only after you have read and understood the contents of this operation manual may you begin work on and with the machine. Keep this operation manual at the application site for future reference.

References to chapters, plans and other documents as well as key markings are written in *italics*.

↓ Instructions on handling are marked in this way.

The machine is designed in modular system and offers a wide spectrum of variations to do justice to your expectations.

This operation manual is divided into three parts:

1. Part A: Information of the basic machine.
2. Part B: Plans, operation manuals for systems from other manufacturers etc.

Should you wish to order further operation manuals, please quote the machine number.

We wish you every success with your new machine!



## **2 TECHNICAL DATA**

### **2.1 ZRS 2600**

|   |                                       |                                     |
|---|---------------------------------------|-------------------------------------|
| Feeding chamber opening:  | Data in mm:                           | 7700x2240                           |
| Rotor dimension:  | Diameter in mm:                       | 2x 1304x                            |
|   | Width of cut in mm:                   | 2530                                |
| Rotor type E  |                                       |                                     |
| Rotor knives:   | No. of rotor knives:                  | 244+248                             |
| Stator knives:  | No. of stator knives:                 | 9                                   |
|   | Rows of stator knives:                | 1                                   |
| Rotor speed (50 Hz):  | rpm                                   | 26                                  |
| Width:  | Data in mm:                           | 4950                                |
| Length:   | Data in mm:                           | 14970                               |
| Height:   | Data in mm:                           | 4625                                |
| Drive motor:  | Power in kW:                          | 4x55                                |
| Motor hydraulic unit:   | Power in kW:                          | 22                                  |
| Range of stage cylinder:  | Data in mm:                           | 8000                                |
| Machine weight:   | In kg                                 | 70000kg                             |
|   |                                       |                                     |
| Electrical connection data:   | markings are attached to the machine  |                                     |
| Noise level:<br>Depends on plant location and<br>type of grinding material! | Without noise equipment,<br>in dB(A): | Approx. 95                          |
|   | With noise equipment<br>in dB(A):     | depends on<br>type of<br>soundproof |



### **3 GENERAL INFORMATION**

#### **3.1 Copyright**

ZERMA Machinery and Recycling Technology (Shanghai) Co. Ltd. holds the copyright for these operation instructions, entrusted to the owner of the shredder for his personal use. This contains technical instructions and drawings which are not be copied complete or in part, distributed or used for reasons of unauthorized competition or for informing others.

#### **3.2 Application**

The shredder is designed for size-reduction of plastic pipes made of PE, PP, and PVC etc. The user is responsible for consequences resulting from incorrect operation: This will lead to the loss of the warranty as well as any compensation claims.

#### **3.3 Safety**

The shredder has been constructed in accordance to the general standards of technology and is fitted with safety devices to prevent accidents that could endanger the life or health of the operator. The company operating the unit is responsible for the compliance to the safety regulations. We recommend staff training courses at regular intervals subsequent to initial training during commissioning.

#### **3.4 Inspection of goods**

The goods must be inspected by the purchaser to ensure that the delivery is complete and free from damage during transport. In the event of any queries Zerma must be informed with regard to missing items or transport damage. In the event of actual transport damage, written notification including photographs should be made and sent to the transport company as well as sent to Zerma immediately after delivery.



---

## **4 GENERAL SAFETY ADVICE**

### **4.1 Safe operation of the machine**

The machine is built according to the state of the art and recognised safety regulations.

It is equipped with protective devices; however there is still the threat of danger in case of incorrect conduct or misuse:

- for the health of the operator and that of other persons,
- for the machine,
- for the environment,
- for material assets belonging to the company and the operator.

All persons involved in:

- transportation and storage,
- start-up and shutdown,
- operation,
- setting and fitting
- maintenance and waste disposal...

of the machine must carefully read and take note of the following advice. However, not only does the general safety advice listed in this chapter need to be observed, but also the safety advice which is added specifically in the other chapters.

Failure to heed this safety advice can lead to loss of all compensation claims.

Furthermore, the existing rules and regulations for the prevention of accidents as well as in house company working, operational and safety regulations have to be observed.



## **4.2 Use in accordance with the regulations**

The operational safety of the delivered machine is only guaranteed for use in accordance with the regulations!

This regulation use is only achieved if the following points are observed and fulfilled.

### **Manufacturing process and grinding material**

The shredder is suitable exclusively for the grinding of pipes, which corresponds to the agreed customer-specific specifications in all points (see *Contract of sale*).

Any other work or design will differ from the specified requirements. Zerma Machinery & Recycling Technology will not be held responsible. The specified requirements also include all information found in the owner's manual such as maintenance and service.

Any change in the specifications or requirements must be brought to the attention of Zerma.

### **Suction unit**

If emissions occur during grinding of material, which exceed the permissible legal values for contaminants in the air, the shredder may only then be operated when the customer has installed a suitable air suction device on site.

### **Safety device for the in feed hopper**

In the case that your design of the shredder does not contain any additional in feed device (e.g. nip roll feed device), the in feed hopper must be safeguarded in a suitable way against persons reaching in or falling in.

If, without our knowledge, the machine is installed "underground" on site, it is deemed to be installation contrary to the intended purpose. The attached manufacturer's declaration alone, stating that the machine may not be operated without additional measures

### **Connection of the Emergency Stop button**

The machine may only be operated with the installed Emergency Stop buttons. In case no Emergency Stop buttons have been installed, an Emergency Stop button must be mounted on the control cabinet, the second on the material in feed.



**Miscellaneous:**

- The working conditions and instructions specified in this operation manual must be adhered to.
- The machine is not suitable for operation in an explosive environment.
- Faults, which can impair safety, are to be reported immediately and eliminated by a trained and skilled specialist.
- The machine may only be used in the industrial application range.

**General Requirements Safety Information**

- The service and maintenance in this owner's manual must be performed on a regular basis.
- The machine is not designed for operation in a volatile environment.
- Faults that could be a safety hazard must be reported immediately and repaired by experienced personal.
- The machine must only be installed in an industrial type building.

**Known uses not in accordance with the regulations**

Never grind materials, which do not correspond to the agreed customer-specific specifications. If this occurs, there could be a danger to persons and the possibility of the machine being damaged.

**Informal Safety Requirements**

The owner's manual should always be located near the machine. New excerpts or additions to the owners' manual must always be inserted to include any safety requirements or environmental requirements.

All safety or caution signs must be visible and easy to read.



### **4.3 Liability and Responsibility**

The General Conditions of Sale and Delivery apply. These conditions apply no later than the end of the contract. Liability and or responsibility to seller do not apply to the following;

- Equipment is not properly used for its specific application.
- Non-conforming installation, commissioning or service of the machines.
- Operation of the equipment without proper safety guards.
- Not conforming to the directions of the owners' manual regarding transport, storage, installation, commissioning or servicing the equipment.
- Any designs alterations on the machine.
- Any changes on the program logic which can alter the machine operation or electrical function.
- Changes in the logic function.
- Improper maintenance or servicing of the machines that can lead to extraordinary wear
- Improper servicing of equipment
- Spontaneous crashes caused by foreign objects falling into the machine or acts of God

We honour a 6 month guarantee valid after delivery under the conditions that originally delivery or original parts from ZERMA Machinery & Recycling Technology are used or accepted for use in accordance with our owners manual.

Otherwise the guarantee will be considered invalid. Excluded are wear and tear parts such as knives, screens, drive belts, bearings, etc.



#### **4.4 Structural changes, spare parts, accessories**

For reasons of safety, remodelling and/or modifications to the machine, in particular to the electrical devices, are only permissible by arrangement with the manufacturer!

Replace faulty parts immediately. Only use original spare parts or spare parts from other manufacturers, which correspond to the original spare parts with regards to function, stress and safety. This applies in particular for reasons of EMC (electro-magnetic compatibility) for electrical components.

The use of unsuitable parts can impair resistance to relays and increase the emission of relays!

If parts are replaced which are relevant for safety, they must be checked afterwards for proper function.

Only use accessories, which have been approved by the manufacturer. Use of accessories can change how the machine works. You must therefore observe the additional advice for your work and your safety. Read *Part B: Accessories*, before you commission the machine.

#### **4.5 Operation manuals from other manufacturers**

Integrated in the machine are systems from other manufacturers. When working on or with these systems, please observe the advice in the operation manuals from the respective manufacturer. These operation manuals are enclosed with the machine documentation.

## 4.6 Noise levels and noise control measures

The ZRS series shredder standard design is without a sound proof enclosure.

The noise level of the shredder at idle speed is approximately 85 dB (A).

Especially by rigid materials soundproofing is recommended due to a noise level of up to 120 dB (A) when in operation.

In order not to exceed the noise level of 85 dB (A) is the purchaser required to provide soundproofing.

The noise level can be affected by foundation static or dynamic, aux. blowers etc. or other additional equipment. Therefore it is necessary to actually determine if the noise level is directly coming from the machine or accessory equipment.

ZERMA Machinery & Recycling Technology offers the following equipment to reduce the noise levels;

- Complete soundproof enclosure.



### **CAUTION**

**The user or purchaser is responsible for compliance with the instructions and procedures!**

## 4.7 Work stations

During normal operation, the work station is the station at the in feed of the grinding material.

For maintenance work, the whole area around the machine is at your disposal.

## 4.8 Remaining risks

The machine is constructed so that you are able to operate it safely. Structurally non-avoidable dangers are prevented as well as possible by the protective devices. A certain remaining risk does however always remain! Being aware of these remaining risks of the machine will help you to structure your work more safely and in so doing to avoid accidents.

To avoid danger, please observe in addition the specific safety advice in the individual chapters.

### 4.8.1 Mechanical dangers

|                               |  |
|-------------------------------|--|
| <b>Type of danger:</b>        | Danger of crushing by heavy parts falling down or falling over.                          |
| <b>Activity:</b>              | Unloading and transporting the machine or machine components.                            |
| <b>Possible consequences:</b> | Serious injury could result.   |
| <b>Preventative measures:</b> | Wear personal protective gear. Follow the instructions in this <i>Operation manual</i> . |

|                               |  |
|-------------------------------|--|
| <b>Type of danger:</b>        | Danger of cutting caused by sharp cutting knives, even when the rotor is stationary.     |
| <b>Activity:</b>              | Knife replacement, knife setting, and knife sharpening, other maintenance work.          |
| <b>Possible consequences:</b> | Serious injury, particularly to hands and fingers can result.                            |
| <b>Preventative measures:</b> | Wear personal protective gear. Follow the instructions in this <i>Operation manual</i> . |

|                               |   |
|-------------------------------|---|
| <b>Type of danger:</b>        | Danger of crushing when opening/closing the maintenance doors on the front side of the machine. |
| <b>Activity:</b>              | Maintenance work.   |
| <b>Possible consequences:</b> | Serious injury can result.  |
| <b>Preventative measures:</b> | Ensure that no persons are in the danger area while closing the door.                           |

|                               |  |
|-------------------------------|--|
| <b>Type of danger:</b>        | Tripping over cables and other objects lying around.                             |
| <b>Activity:</b>              | All activities.  |
| <b>Possible consequences:</b> | Serious injury can result.   |
| <b>Preventative measures:</b> | Lay cables in accordance with the regulations. Keep work station clean and tidy. |

|                               |   |
|-------------------------------|---|
| <b>Type of danger:</b>        | Danger of crushing, cutting and amputation caused by run down of the rotor.   |
| <b>Activity:</b>              | Maintenance work.   |
| <b>Possible consequences:</b> | Serious injury or death can result.   |
| <b>Preventative measures:</b> | The maintenance doors must always be tightly locked during operation. Do not make the run down safety devices ineffective by using technical aids or other manipulations. Never check by hand whether the rotor has come to a stop. |

|                               |   |
|-------------------------------|---|
| <b>Type of danger:</b>        | Danger of pulling in caused by running "V"-belts.                               |
| <b>Activity:</b>              | All activities.   |
| <b>Possible consequences:</b> | Hair, jewellery etc. can be pulled into the machine. Serious injury can result. |
| <b>Preventative measures:</b> | Never dismount "V"-belt protection and window.                                  |

**4.8.2 Electrical dangers**

|                               |   |
|-------------------------------|---|
| <b>Danger:</b>                | Direct or indirect contact with live parts in the terminal box.   |
| <b>Activity:</b>              | Maintenance work, start-up.   |
| <b>Possible consequences:</b> | Serious injury or death.  |
| <b>Preventative measures:</b> | Only trained electricians may only carry out all work on the electrical equipment.<br>If work is necessary on parts, which conduct dangerous voltage, a second person should be called in who can break the power supply in case of emergency.<br>The yellow-marked lines conduct voltage even when the machine is switched off (main switch to 0).<br>Only use original safety fuses with stipulated intensity of current.<br>Faulty electrical components must be replaced immediately.<br>If faults occur in the electrical energy supply, switch machine off immediately.<br>The terminal box must be locked during operation. Before opening the terminal box: Main switch to 0. |

#### 4.8.3 Dangers caused by the control system

|                               |  |
|-------------------------------|--|
| <b>Type of danger:</b>        | Danger caused by failure of the Emergency Stop function.   |
| <b>Activity:</b>              | All activities.  |
| <b>Possible consequences:</b> | Serious injury or death.   |
| <b>Preventative measures:</b> | It must be guaranteed that failure of an Emergency Stop button is displayed and leads to an immediate stop of the machine. |

#### 4.8.4 Thermal dangers

|                               |  |
|-------------------------------|--|
| <b>Type of danger:</b>        | Danger of fire and explosion caused by throwing dangerous objects (e.g. spray cans) into the shredder. |
| <b>Activity:</b>              | Grinding.  |
| <b>Possible consequences:</b> | Serious injury or death can result.  |
| <b>Preventative measures:</b> | Only grind material which corresponds to the agreed customer-specific specifications in all points.    |

#### 4.8.5 Dangers caused by noise

|                               |  |
|-------------------------------|--|
| <b>Type of danger:</b>        | Damage to hearing.   |
| <b>Activity:</b>              | All activities.  |
| <b>Possible consequences:</b> | Diminished hearing, headaches, impaired balance, and deterioration of concentration. |
| <b>Preventative measures:</b> | Reduce noise emissions by taking suitable measures. Wear ear protection.             |

#### 4.8.6 Dangers caused by vibration

|                               |   |
|-------------------------------|---|
| <b>Type of danger:</b>        | Instability of the machine caused by vibration.   |
| <b>Activity:</b>              | All activities.   |
| <b>Possible consequences:</b> | Serious injury can result.  |
| <b>Preventative measures:</b> | Install the machine according to the instructions of this <i>Operation manual</i> and the <i>Assembly drawing</i> . |

|                               |   |
|-------------------------------|---|
| <b>Type of danger:</b>        | Loosening of the cutting knife mountings caused by vibration.                                       |
| <b>Activity:</b>              | All activities.   |
| <b>Possible consequences:</b> | Serious injury can result.  |
| <b>Preventative measures:</b> | Check the cutting knife mountings regularly according to the instructions in this operation manual. |

#### **4.8.7 Dangers caused by materials and substances**

|                               |   |
|-------------------------------|---|
| <b>Type of danger:</b>        | Inhalation of grinding dust.  |
| <b>Activity:</b>              | All activities.   |
| <b>Possible consequences:</b> | Diseases of the respiratory tract etc.  |
| <b>Preventative measures:</b> | Mount a suitable air suction device. Wear breathing equipment if necessary. When cleaning the machine do not blow out grinding dust, use suction instead. |

#### **4.8.8 Danger caused by manipulation of the protective devices**

|                               |  |
|-------------------------------|--|
| <b>Type of danger:</b>        | Danger of crushing, cutting and amputation.  |
| <b>Activity:</b>              | All activities.  |
| <b>Possible consequences:</b> | Serious injury or death can result.  |
| <b>Preventative measures:</b> | Never make the protective devices ineffective. Check the protective devices regularly for proper functioning according to the specifications given in this operation manual. |

## 4.9 Protective devices

The machine may under no circumstances be operated without these protective devices or with faulty or manipulated protective devices.

### 4.9.1 Safety device for housing flap

Illustration:

- (1) Safety devices for lower housing flaps
- (2) Safety devices for upper housing flaps

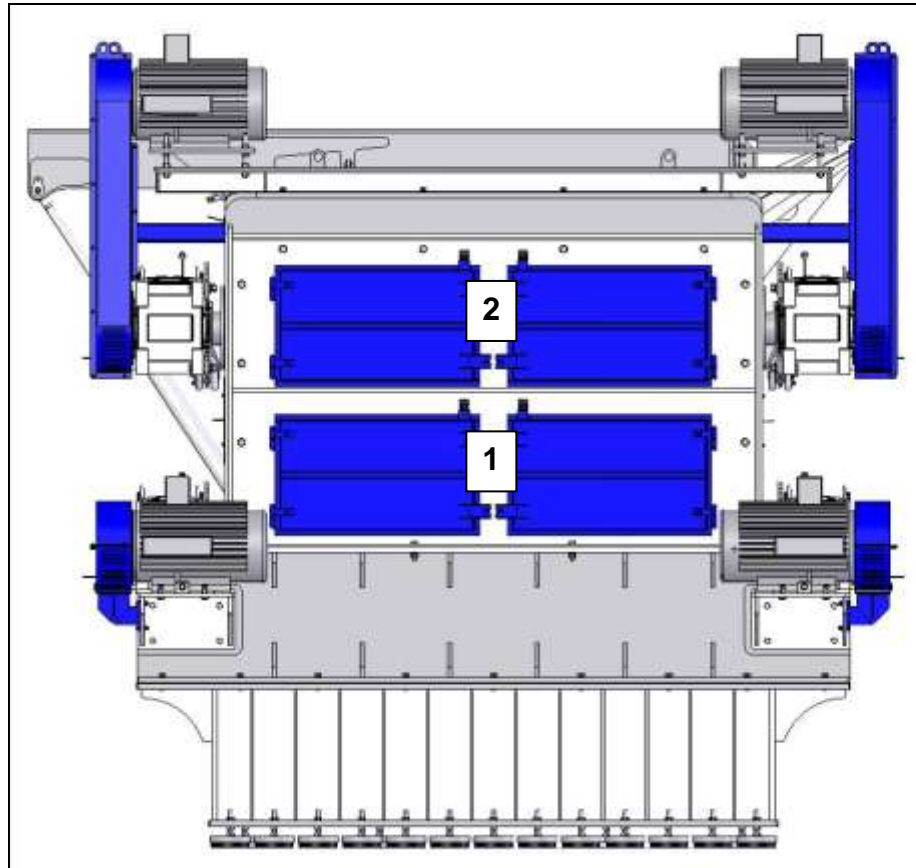

The shredder can only be operated if the housing flap is closed thus deactivating the safety switch. If the housing flap is opened, the contact is broken.

If the housing flap will be opened during operation, the safety switch is activated, thus switching off the machine.

#### 4.9.2 "V"-belts and pusher protector

"V"-belt and pusher protection are fixedly connected to the machine. They can be dismantled for installation and maintenance work. However, this may only then be carried out when all rotating parts have come to a complete standstill.

Illustration:  
V-belt covers  
Pusher covers

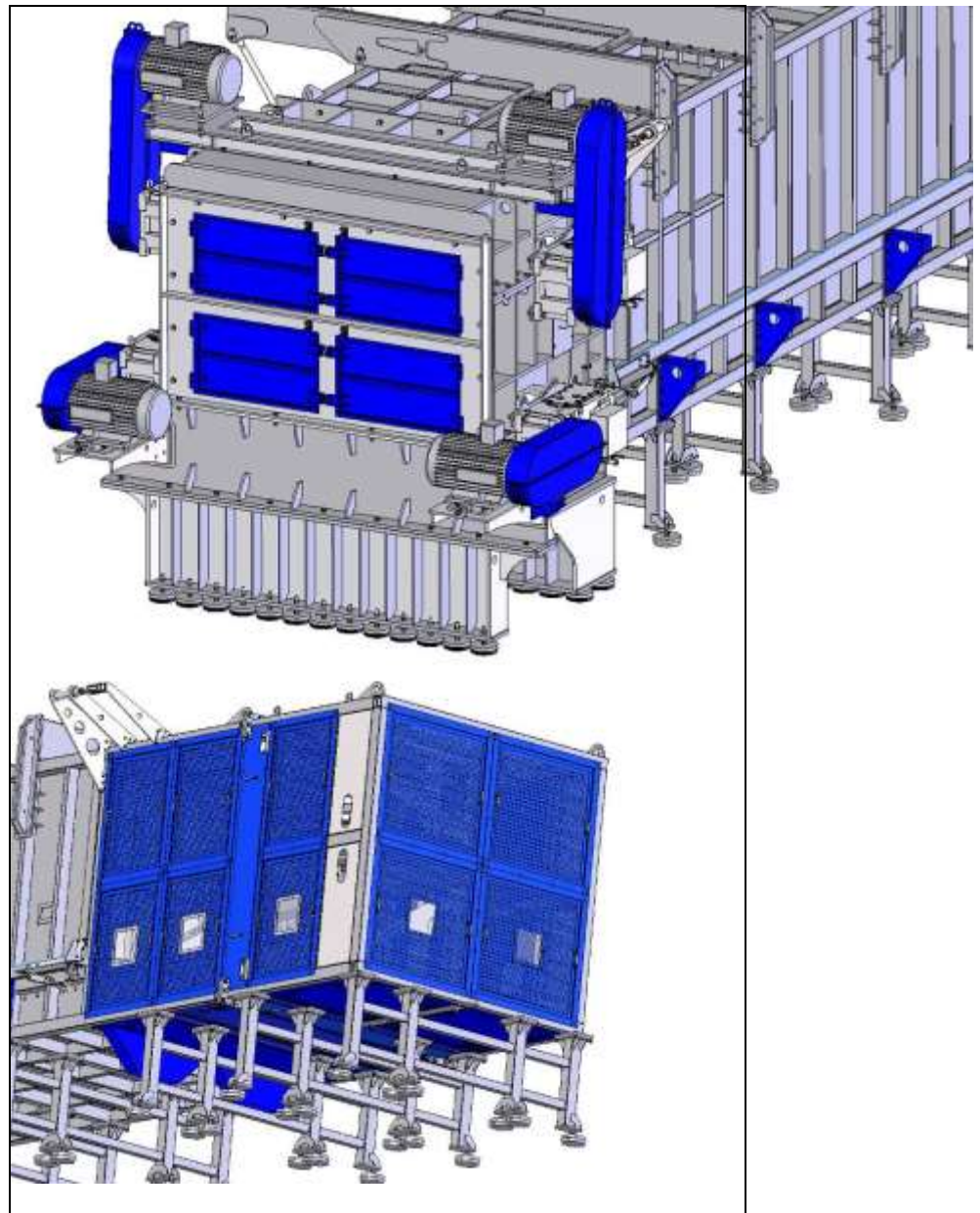

If machines are delivered on the request of the customer without drive motors, the operator is obliged to fit and mount the protective devices delivered together with the machine himself in line with the current legal safety regulations.

#### **4.9.3 Safety Light grid**

The feeding trough in feed is safeguarded by a light grid. During opening and closing of the cover it is activated. If somebody walks inside this light grid, the hydraulic will be stopped. After the cover is opened or closed the light grid is deactivated.

Illustration:  
Safety fence



#### **4.9.4 Hopper safety lock**

The feeding trough lid can be safeguarded by a lock bolt when at open position. For ZRS800-1500 this lock is manually operated. For the ZRS2000 the lock is operated by pneumatic. When the lock is activated, the hydraulic unit is shut off.

Illustration:  
Safety lock for lid

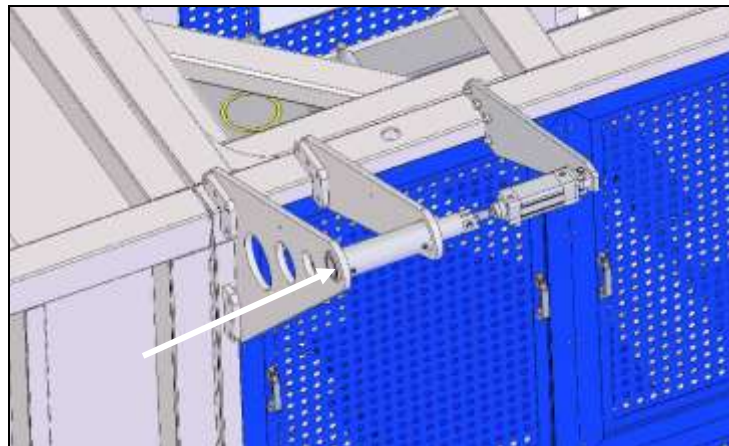

#### **4.9.5 Safety markings**

Safety markings are attached to the machine. If one of these markings becomes detached or is no longer recognisable, it must be replaced. You can order new markings at specialist shops or from us.



#### **4.10 Authorized persons**

Only authorized personnel may only carry out work on the machine. Observe the legally permissible minimum age!

As a basic rule, only persons who have received training on the machine may only operate the machine.

Personnel, who are still to be trained or receive instruction on the machine, may only work on the machine under constant supervision by an experienced person.

The company operating the machine must make the operation manual accessible to the machine user and ensure that he has read and understood it. Only then may he put the machine into operation.

Responsibility for the different jobs on the machine must be clearly established and adhered to. There must be no unclear areas of authority, as this could endanger the safety of the machine user.

If several persons work on the machine, a detailed division of workstations should be set up.

Only trained electricians may only carry out all work on the electrical equipment.

Only authorized specialist personnel may only eliminate faults on the control system.

All work related to installation, only trained specialist personnel having received instruction on the machine might only carry out fitting and maintenance of the machine.

The operator must make sure that only authorized personnel work on the machine. The operator is responsible for the safety of third persons in the working area of the machine.



#### **4.11 Personal protective gear**

Wear close-fitting clothing. Jewellery and hair must be worn so that they cannot be pulled into the machine by moving parts.

**The following protective gear must be worn when carrying out the following tasks:**

|                                | <b>Safety helmet</b> | <b>Safety boots</b> | <b>Safety gloves</b> | <b>Safety goggles</b> | <b>Ear muffs</b> |
|--------------------------------|----------------------|---------------------|----------------------|-----------------------|------------------|
| Unloading machine.             | x                    | x                   | x                    |                       |                  |
| Connecting machine.            |                      | x                   |                      |                       |                  |
| Operation.                     | x                    | x                   | x                    | x                     | x                |
| Cleaning.                      |                      | x                   | x                    | x                     |                  |
| Maintenance of bearings.       |                      | x                   |                      |                       |                  |
| Maintenance of "V"-belts.      |                      | x                   |                      |                       |                  |
| Maintenance of cutting knives. |                      | x                   | x                    |                       |                  |
| Knife sharpening.              |                      | x                   | x                    | x                     | x                |

If necessary, protect yourself with breathing equipment (in addition to the air suction device) before inhaling substances harmful to the health.

#### **4.12 Safety measures at the application site**

Requirements at the application site: see chapter *Initial Start-up*.  
The machine must be erected horizontally on a horizontal surface and in a stable manner.

Ensure by means of appropriate in house orders and controls that the environment of the work station is always clean and clear of obstructions.

#### **4.13 Fire fighting agents**

In the case of fire, disconnect the power supply of the machine or pull out the mains plug. Extinguish the fire from a distance of several meters using a fire extinguisher suitable for the machine and the grinding material.

#### **4.14 Cleaning agents**

Only use suitable cleaning agents to clean the machine and in doing so, the advice of the manufacturer is to be heeded. Please be aware that unsuitable cleaning agents (e.g. thinners) can damage the paint of the machine as well as the cables and plastic parts.

#### **4.15 Conduct in case of an emergency**

The machine may only be operated with the installed Emergency Stop buttons. An Emergency Stop button must be mounted onto the control cabinet, the second onto the grinding material in feed.

##### **Emergency Stop:**

- ↓ In case of emergency, immediately press one of the *Emergency Stop buttons*.

## **CAUTION**

**The EMERGENCY STOP must be activated in all situations whereby injury or damage could result!**







##### **Reoperation:**



- ↓ Eliminate cause of Emergency Stop.
- ↓ Unlock *EMERGENCY STOP BUTTON*.
- ↓ Acknowledge fault.  
The machine is now ready for operation again.

#### 4.16 Classification of specific safety advice

The specific safety advices in the following chapters of this operation manual are classified as follows:

|  <b>DANGER</b> |   |
|---|---|
|                | Indicates an immediately threatening danger. If you do not take avoiding action, death or serious injury will result. |

|  <b>WARNING</b> |   |
|--|---|
|                | Indicates a possibly dangerous situation. If you do not take avoiding action, death or serious injury could result. |

|  <b>CAUTION</b> |  |
|--|--|
|                 | Indicates a possibly dangerous situation. If you do not take avoiding action, slight or minor injury could result. |

This safety advice refers to the remaining risks for certain working steps and helps you to work safely with the machine. In addition to the safety advice above, there are also the hint and the tip.

### HINT



Indicates a possibly harmful situation. If you do not take avoiding action, the machine could be damaged.

### TIP



Indicates application tips and other particularly useful information.



## **5 DESCRIPTION OF THE MACHINE**

### **5.1 Functional description**

#### **5.1.1 Mechanical section**

After the machine has been switched on, a hydraulically controlled feeding unit pushes the pipe onto the slow-running rotor. The in feed is controlled according to the load of the motor.

The pipes can be fed horizontally and without precutting into the feeding trough of the pipe shredder by a forklift or optionally with a loading device. The feeding trough has a hydraulically operated cover, which is closed after it is filled with material. A hydraulic ram system is then pushing the material towards the rotor. The ram consists of a double-acting telescopic cylinder and the pusher itself, which is a heavy durable welding construction. The pusher is moving on 3 sets of high performance guide roller skids. Those adjustable skids are running on 3 independent guide rails.

The trough is built with tough steel profiles and all safety features are according latest CE-standards for work safety.

The pipe should be placed horizontally in the feeding trough mounted next to the cutting chamber. Attention must be paid that this material does not contain **any metal parts**. The guarantee does not cover any damage to the machine as a result of metal parts being fed into the machine. The pipe in the feeding trough is shredded by the rotating knives on the rotor. This shredding process is finished when the hydraulic cylinder has reached its full stroke and the pusher is at the end position.

The ZRS series shredder is equipped with a Zerma E style rotor using Zerma's standard square, concave cutter blocks. These cutters make light work of the heaviest pieces. Importantly, the design allows efficient cutting of material, rather than hammering as well as reduced heat build-up and degradation of material. The cutter blocks have four corners so they can be easily turned once a corner has worn away.

The projection of the cutter can be easily adjusted to match the aggressiveness of the shredder with the customer's material by adding or removing thin shims on the cutters holder.

The housing is a rigid welded and very compact construction. Upper and lower part of the housing are bolted together and this makes maintenance work very convenient. The housing is sitting on a base frame, which allows easy installation of a discharge conveyor.



Due to the compact design this machine can only be used for screen-less operations!

The heavy-duty outboard bearings mounted on the ZRS shredders minimize the risk of contamination of the recycled materials and also minimize the risk of dust penetrating the bearings and make a rotor change easier.

Power is transmitted from the electromotor by V-belts to the gearboxes, which are mounted directly on the shaft end on either side of the rotor. In combination with the elastically supported torque arm this construction will reduce stress to both motor and gear.

The dual drive will further ensure that all loads are evenly distributed into the rotor.

### **5.1.2 Control**

The pusher feeds the rotor with as much material as it is able to process. Upon reaching 70% of rated current, the feeding of the pusher will be stopped and automatically started again after the power consumption has fallen by 20 % in comparison with rated current. If the high current is applied for longer than 0.7 - 1.5 sec., the main drive motor switches off and runs back after about 3 sec. standstill time. The pusher plate also runs back whilst the rotor runs back. The drive motor then stops for another 3 sec. before starting again.

The position of the pusher is controlled by an optical distance sensor. The in feed is controlled according to load.

Duration of pauses and return as well as the current settings can be adjusted.

**Any alterations, however, should only be carried out after consulting the manufacturer.**

## **5.2 Grinding material in feed**

The grinding material can be fed into the shredder in the following ways:

- Manual in feed of the grinding material directly into the feeding trough
- Manual in feed of the grinding material with the help of an additional in feed device (e.g. hydraulic feeding unit).

### **5.2.1 Feeding trough for side feed**

The grinding material in feed ensues via a feeding trough. The pipe can be placed easily in the feeding trough by a forklift

Illustration:

Feeding trough



The feeding trough has a hydraulically operated cover, which is closed after it is filled with material. A hydraulic ram system is then pushing the material towards the rotor.

**PART A: Basic machine**  
**Shredder**  
**ZRS2600**



Illustration:

- (1) Stage cylinder
- (2) Cover
- (3) Lock
- (4) Pusher
- (5) Chamber
- (6) Lid

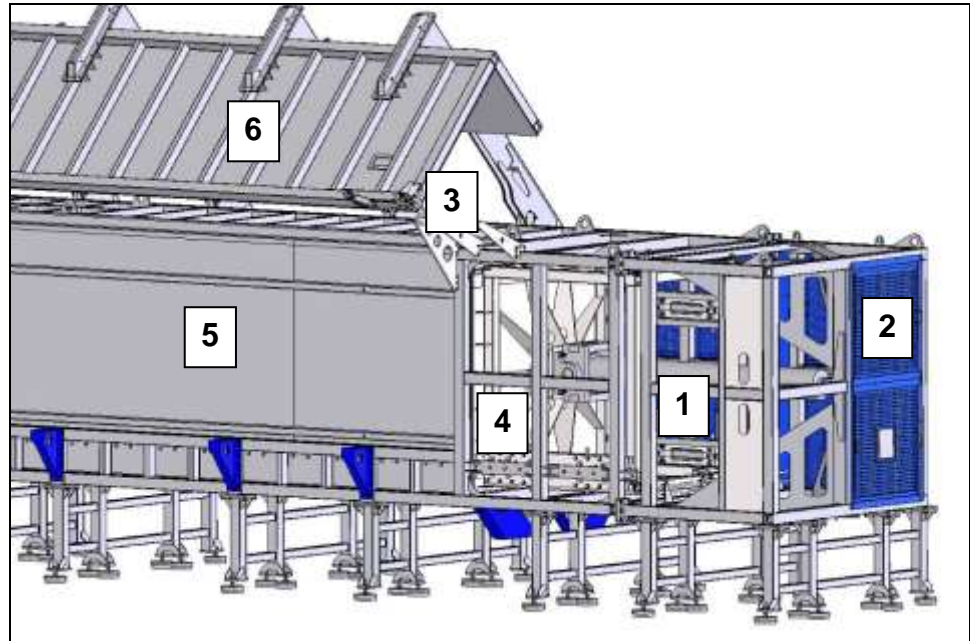

Optional (not included in standard machine) the feeding trough can be equipped with a hydraulic feeding device.

**5.3 Shredder**

Illustration:

- (1) Base frame
- (2) Lower housing flaps
- (3) Upper housing flaps
- (4) Gear box
- (5) Drive motor
- (6) V-belt cover
- (7) Discharge are for conveyor

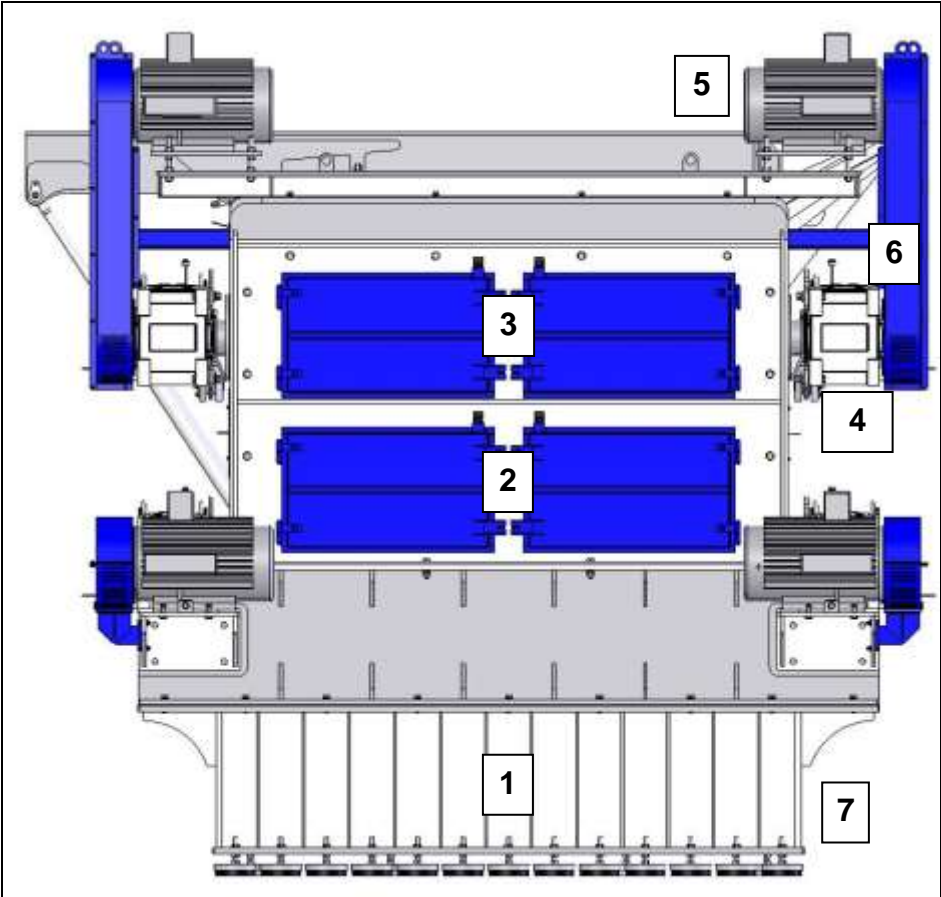

The machine housing is mounted on the base frame and the drive motor and the gear box are mounted on the machine housing. This design makes the machine compact. Below the rotor a conveyor discharges the material.

## 5.4 Drive

The drive of the rotors ensues by means of an electric motor via "V"-belts. The motors, which are mounted on sliding rails or a motor plate, can be adjusted for regulating the tension of the "V"-belts by means of tensioning screws. The "V"-belt pulley is attached with a special tensioning element to the motor shaft.

Illustration:  
Drive

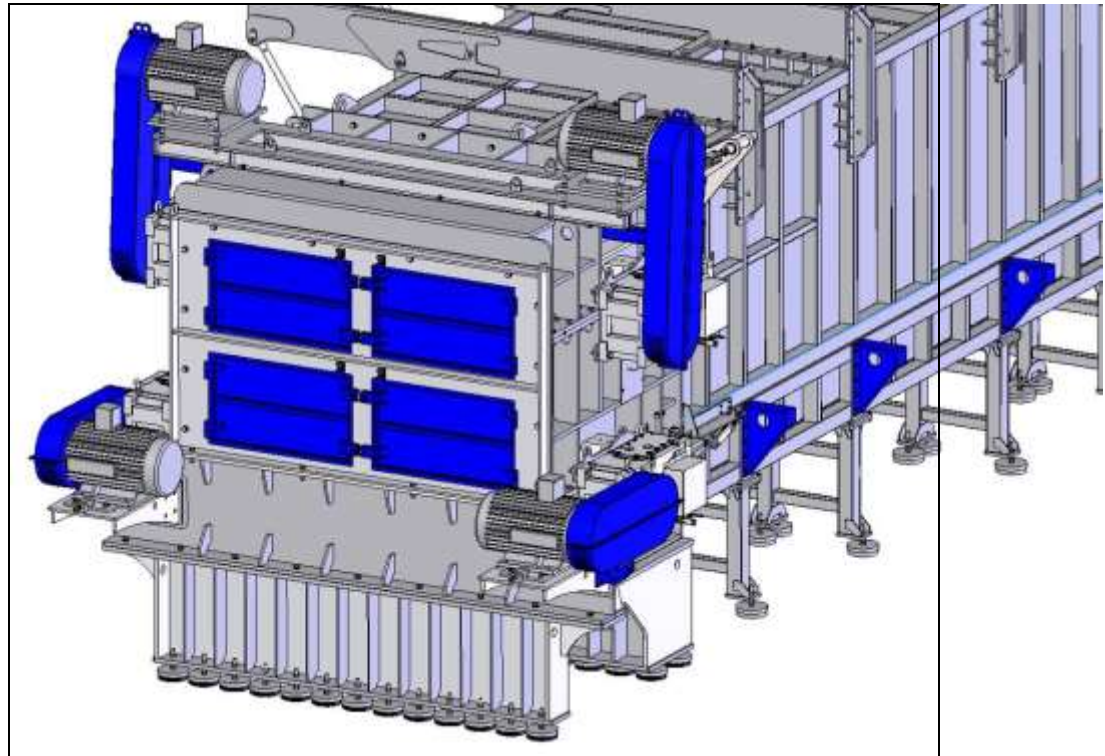

Please observe the operation manual from the manufacturer!

## 5.5 Rotor and knives

The material is ground between the knives assembled on the rotor and the stator knives which are mounted in a fixed position in the machine lower section.

All rotors are equipped with square knives. These knives make light work of the heaviest pieces.

The knives have four corners, so that they can be easily turned once a corner has worn off.

The design of the rotor has a significant influence on the quality of the grinding process and its results. The rotor construction, the type of knife mounting and the number of knives have all been exactly matched to your task allocation.

Illustration:

- (1) Rotor knife
- (2) Stator knife
- (3) Discharge area

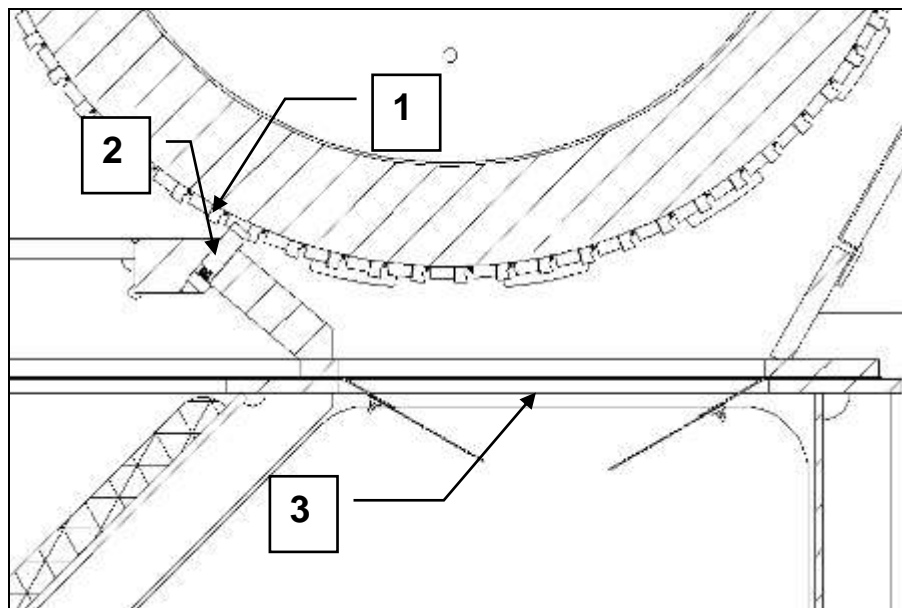

Due to the compact design this machine can only be used for screen-less operations!

The rotor is accessible after opening the lower housing flap or the upper housing flap.

The rotor is arranged on roller bearings, which are situated outside the housing. The "V"-belt pulley is attached by means of a taper bush to the rotor axis. The rotor is dynamically counter balanced and has vibration-free concentricity.

## **5.6 Pre-breaker for thin-walled pipe/profile (optional)**

A pre-breaker can be installed in front of the rotor, above the stator knife, for pre-cutting for thin-walled pipe and profile. This wedge will prevent that thin material makes it through the rotor without being cut.

Illustration:

Wedge

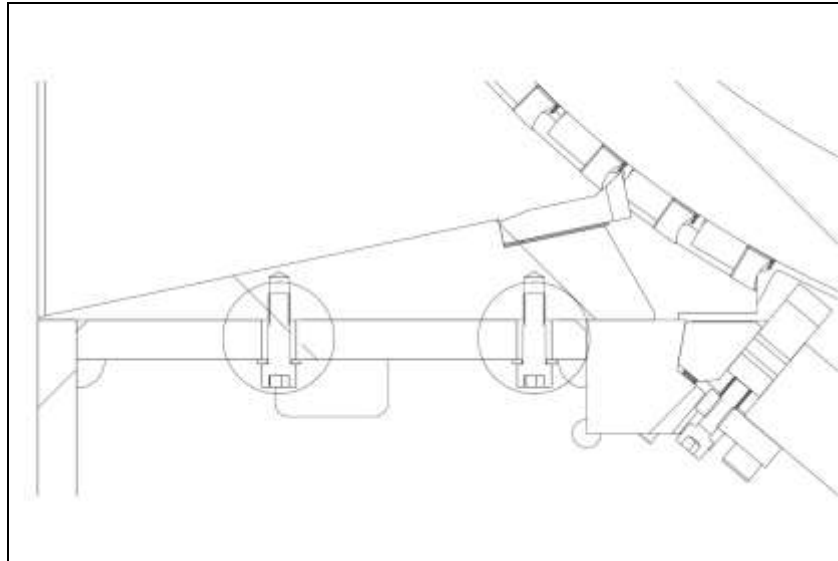

The wedge has a hook knife design and need to be replaced together with the rotor and stator knives.

## **5.7 Discharge of grinding material**

Illustration:

Conveyor belt discharge



The ground material will be discharged by a conveyor belt.

## 5.8 Hydraulic pusher

The ram consists of a double-acting telescopic cylinder and the pusher itself, which is a heavy durable welding construction. The pusher is moving on 3 sets of high-performance guide roller skids. Those adjustable skids are running on 3 independent guide rails. The position of the pusher is controlled by an optical distance sensor.

Illustration:

- (1) Hydraulic stage cylinder
- (2) Guide roller
- (3) Guide rail
- (4) Pusher

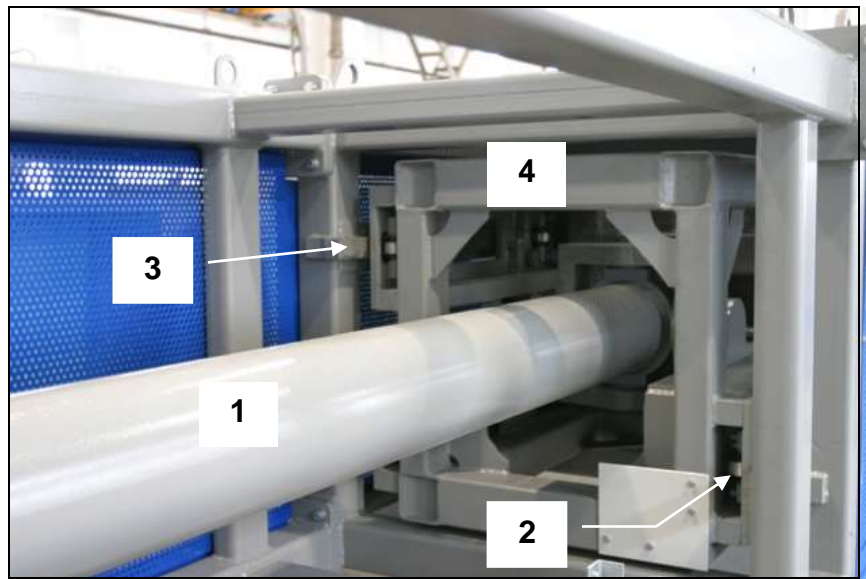

Illustration:

- (1) Pusher front plate
- (2) Guide rail



Illustration:

- (1) Distance sensor
- (2) Reflecting area

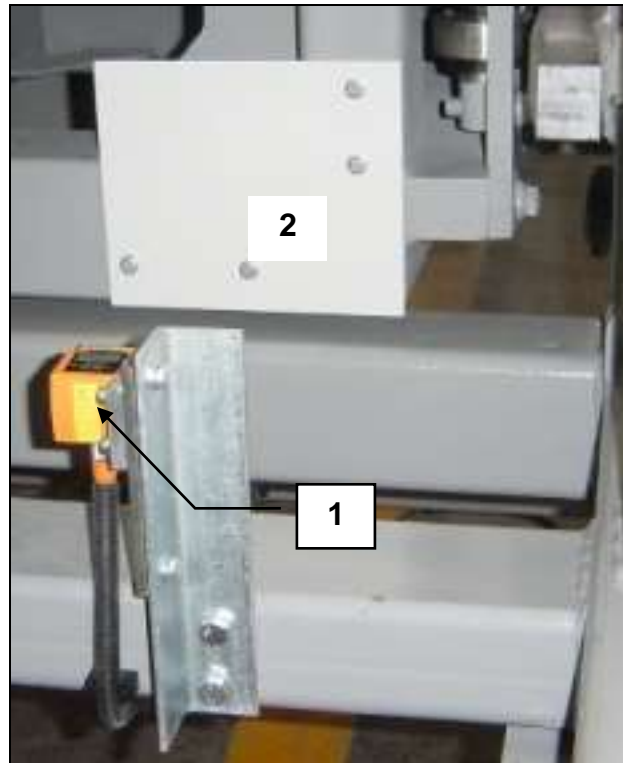



## **5.9 Control and operator panel**



Please observe the Wiring diagram and the Operator/Control manual



## 6 INITIAL STARTUP

### 6.1 General Advice

**All work related to start-up may only be carried out by trained specialist personnel.**

Check the machine for possible transportation damage or other damage. Should you determine damage, have this confirmed by the freight company and please report this to us in writing immediately after delivery. When starting up for the first time and after setting up ready for service, you must carry out the necessary checks according to the chapter *Machine Check prior to Initial Start-up*.

|  |  |
|--|--|
|  <b>WARNING</b> |  |
|                | <p><b>Check the oil level of the gear box, before operating the machine.</b><br/><b>Please observe the operation manual from the manufacturer!</b></p> |

|  |   |
|--|---|
|  <b>WARNING</b> |   |
|                 | <p><b>Fill oil into the hydraulic tank.</b><br/><b>Please observe the operation manual from the manufacturer!</b></p> |



## **6.2 Requirements at the application site**

The site of application for the machine must exhibit the following features:



- Enclosed space.
- The ground must exhibit sufficient load-bearing capacity (you can find the machine weight in the *Chapter Technical Data*). The unevenness of the ground surface may not exceed 5 mm.
- The machine must be freely accessible from all sides.
- There must be sufficient room available for operating and service personnel.
- Spatial requirements: see *Assembly drawing*. All hinged parts must be able to be opened completely.
- Vibration-free environment.
- The application site must be well-lit.
- The machine may not be exposed to direct radiation caused by radiators or the sun.
- Room temperature: +5° to +40°C
- Relative atmospheric humidity according to DIN 40040:  
15 to 70 % (indoor)  
By humidity levels higher than 70 %, apply anticorrosive agent to the metallic-finished machine parts. Insulation for the tropics is also necessary.
- The machine may not be operated within range of static discharges or strong magnetic fields as this could lead to faults in the machine control system.

### 6.3 Unloading and installing the machine

The machine or the machine components are packed so that they will arrive to you safely. To see how the machine is packed or should be packed, please see the *Packing plan*. For unloading the packaged machine or machine components you may use a suitable crane or forklift.

|  <b>WARNING</b> |   |
|--|---|
|                 | <b>Suspended load.</b><br><b>Falling loads can cause serious injury or death.</b><br><b>Only use a crane or a forklift which is suitable for the weight and the dimensions of the load.</b>                           |
|                 | <b>Also use a suitable stopping means and pay attention to the gravity centre location.</b><br><b>Do not step under the suspended load.</b><br><b>Wear a safety helmet in addition to your basic protective gear.</b> |



- ↓ After unloading, remove the packaging material and all transportation safety devices.
- ↓ In the case that the shredder and its accessory components have been delivered as individual items, mount these at the site of ap
- ↓ in accordance with the data given in the *Assembly drawing*. Only in this way can it be guaranteed that there are sufficient delivered piping parts, tubing and cable connections and that the linking places match.

|  <b>WARNING</b> |   |
|--|---|
|                 | <b>Overturning or falling machine.</b><br><b>Serious injury or death can result.</b><br><b>In the case that you wish to erect the granulator over a pit, on a frame or on a platform, you must secure the machine by putting mounting screws through the holes on the mounting pads (see <i>Assembly drawing</i>). If assembling the machine on solid ground, this safety device is not absolutely necessary.</b> |

- ↓ Align the machine horizontally with the help of a suitable spirit level.  
Do not use blocks to place underneath the machine, use instead metal strips in order to prevent buckling of the base frame. Make sure that an even distribution of weight is achieved on all the points of support.



## 6.4 Electrical connection

Electrical connections should only be made by a qualified electrician.

|  |  |
|--|--|
|  <b>WARNING</b> |  |
|                 | <p><b>Dangerous voltage.</b><br/>Touching live parts can lead to serious injury or death.<br/>All work which relates to the electricity of the machine may only be carried out by trained electricians.<br/>Observe the currently effective EMC regulations.</p> |

Voltage, current, frequency and protection are marked on the *Type plate*. The voltage tolerance is  $\pm 10\%$ .

- ↓ For machines which have not been pre-wired by ZERMA, the electrical connection is to be carried out in accordance with the enclosed *Wiring diagram* in the terminal box. When doing this, the regulations of the local electricity authority are to be adhered to. The cable cross section required is to be determined according to the rated capacity of the units.

|  |   |
|--|---|
|  <b>WARNING</b> |   |
|                 | <p><b>When operating specific equipment caution must be taken to prevent electrical shock. Installation, service, alterations and or modifications must only be done by qualified personal and with high regard for safety. Not conforming to the requirements could result in bodily injury, death or costly damage.</b></p> |



## HINT

Alterations to the wiring diagrams from ZERMA require our approval. Failure to do this will exclude all guarantee claims.

The wiring schematics are located in the control panel in the event that the control panel is a part of the delivery.

### **Connection of Emergency Stop button**

The machine may only be operated with installed Emergency Stop buttons. In the case that no Emergency Stop buttons have been installed at the factory, an Emergency Stop button must be installed at the control cabinet, the second at the grinding material in feed.



## **HINT**

**The control panel with the switches and Emergency Stop button should be installed nearby the machine. The distance should not exceed 5 m.**

**The connecting cables between control panel and machine have to be protected against damage (cable tray, protective sleeve).**

**If the control box cannot be installed according to this rules an additional Emergency Stop button has to be installed on the machine.**

### **Checking the rotational direction**

Rotational direction of the motors must be checked before initial start-up (see chapter of same name). The steps prior to this check must be completed.

- ↓ Switch the machine on and then immediately off again (see *Switch on machine* and *Switch off machine*).
- ↓ Observe whether the discharge air fan in the drive motor is rotating in the direction of the direction arrow.



## **HINT**

**If running in the wrong direction, reconnect the motor connection immediately. Damage to the machine will result from operation in the wrong direction.**

## 6.5 Machine check prior to initial start-up

| Check   | See chapter  |
|---|--|
| 1. When the housing flaps are opened, check the knife mounting screws using a torque wrench.  | <i>Replacing and checking the cutting knife mountings.</i> |
| 2. Search the grinding chamber for foreign matter.  | <i>Cleaning the machine</i>                                |
| 3. Close housing flaps and fasten screws tightly.   |  |
| 4. Check oil level of the gear box  | <i>Hydraulic Maintenance</i>                               |
| 5. Fill in oil into the hydraulic unit  | <i>Hydraulic Maintenance</i>                               |
| 6. Check that the <i>Emergency Stop buttons</i> are unlocked.   |  |
| 7. Check all safety devices for proper functioning.   | <i>Checking the protective devices.</i>                    |
| 8. Switch on machine for a short time and check rotational direction. The rotational direction can be seen at the discharge air fan of the drive motor (observe running direction arrow). | <i>Electrical connection.</i>                              |
| 9. Switch on hydraulic unit for a short time and check rotational direction.  | <i>Hydraulic pusher</i>                                    |
| 10. Allow machine to run for approx. 10 minutes without grinding material.  | <i>Switch on machine.</i>                                  |
| 11. Connect material discharge device (accessories), check rotational direction drives.   | <i>Part B: Accessories.</i>                                |
| 12. Feed grinding material uniformly. Too much grinding material can lead to overload of the machine.   | <i>Manual in feed of grinding material.</i>                |
| 13. If necessary, check the temperature of the ground material.   |  |
| 14. Monitor the ammeter. This displays the present current consumption and in this way gives information on the load of the machine.  |  |

## **7 OPERATION**

**Have you read and understood the operation manual, in particular the safety advice in the Chapter Four?  
You may not operate the machine until you have done so!**

### **TIP**



**Should faults occur during work with the machine, please observe the advice in the chapter *Troubleshooting*.**

### **7.1 Machine checks before switching on the machine**

| <b>Check</b>  | <b>See</b>   |
|---|--|
| 1. The knives are properly set and the screws are tightened with the specified torque.                | <i>Replacing and checking the cutting knife mountings.</i> |
| 2. The grinding chamber is free of foreign matter.  | <i>Cleaning the machine.</i>                               |
| 3. The housing flaps are closed.  |  |
| 4. All safety devices, including those of the installed discharge devices, are checked and operative. | <i>Checking the protective devices.</i>                    |



### **7.2 Switch on machine**

1. Switch on the grinding material discharge device.
2. Switch on the machine (main switch to 1).
3. Set to automatic on the control board
4. After cover is opened put in the pipe
5. Press button "System on" to start cycle
6. Machine will operate automatically

### **7.3 Switch off machine**

1. Wait until the cycle is finished and the cover has opened.
2. Then switch off the shredder, (main switch to 0).
3. If you want to close the cover of the feeding trough, close it manually by pressing the button cover close.
4. Switch off the grinding material discharge device.

### **7.4 Manual in feed of grinding material**

|   |   |
|---|---|
|  <b>DANGER</b> |   |
|               | <p><b>Rotating knives.<br/>Can cause serious cutting and crushing injuries, possibly leading to death.<br/>Do not climb into the feeding trough when it is opened and the machine switched on.<br/>You will die.<br/>Do not walk inside the light grid area when opening the cover.</b></p> |

↓ Put material into the feeding trough than start the cycle.

The machine should be feed from the front.



During opening and closing of the cover, the safety light grid is activated. The hydraulic will stop when somebody reaches in this light grid.



**8 MAINTENANCE**

**8.1 Safety advice**

**Trained specialist personnel may only carry out work included within the framework of maintenance.  
Carry out the maintenance work within the specified time and document this. The machine will thank you for this by providing high reliability.**

|  <b>WARNING</b> |  |
|--|--|
|                 | <b>Danger caused by electrical voltage and starting the machine during maintenance work.<br/>Mortal danger.</b>                                |
|                | <b>Therefore, as a basic rule when carrying out maintenance work:<br/>Main switch to 0, safeguard using padlock and attach a warning sign.</b> |

## 8.2 Maintenance plan

The tasks for maintenance work are described in detail in this chapter.

| Maintenance work  | Oh = Operation hours                                       |            |             |
|---|--|------------|-------------|
|   | Every day  | Every week | Every month |
| Check protective devices for proper functioning.                | x  |            |             |
| Clean machine.  |  |            | x           |
| Check cutting knife mountings.                                  | x  |            |             |
| Check the main bearings (bearing clearance, lubricant renewal). |  |            | x           |
| Lubricant replacement, lubricant renewal                        | <b>See Lubrication intervals:</b>                          |            |             |
| Check "V"-belt tension force and "V"-belt condition.            |  | X          |             |
| Check condition of cutting knives.                              | x  |            |             |
| Check all screws of the machine for a tight fit.                |  | X          |             |
| Check wearing parts.  |  | X          |             |
| Check hydraulic oil level and consistence                       |  | X          |             |
| Change hydraulic oil  | 1 <sup>st</sup> time after 1000 Oh than after every 2000Oh |            |             |
| Check gearbox oil level   | Every 2000 Oh  |            |             |
| Change side of stage cylinder                                   | Every 2000 Oh  |            |             |

### Yearly maintenance



The purpose of yearly maintenance of the machine is primarily to check the general condition of the machine and to arrange for the supply of any necessary replacement parts in good time. A service engineer from ZERMA Machinery & Recycling technology can also carry this out on request.

### **8.3 Checking the protective devices**



For this, see also the chapter *Protective devices*.

Check the safety devices for:

- Stipulated condition,
- Stipulated location,
- Safe mounting,
- Stipulated function.



|  |   |
|--|---|
|  <b>WARNING</b> |   |
|                | <p><b>Danger due to non-functioning protective devices.<br/>Serious injury or death can result.</b></p> <ul style="list-style-type: none"><li>• <b>Eliminate all defects before you put the machine into operation!</b></li><li>• <b>If defects occur during operation, stop the machine immediately and eliminate the defects!</b></li><li>• <b>Do not change or remove any protective devices. Do not put any protective devices out of action by modifying them.</b></li></ul> |

## 8.4 Cleaning the machine

|  |  |
|--|--|
|  <b>WARNING</b> |  |
|                 | <p><b>Danger of cutting caused by sharp cutting knives, even when the rotor is at a standstill.<br/>Serious injury, particularly to hands and fingers, can result.<br/>Wear protective gloves.</b></p> |

**Proceed as follows:**

- ↓ Switch off the shredder at the main switch
- ↓ Safeguard main switch using a padlock.
- ↓ Open the housing flaps.
- ↓ Safeguard the housing flap.
- ↓ Open the cover of the feeding trough
- ↓ Safeguard the cover

|   |  |
|---|--|
|  <b>WARNING</b> |  |
|                | <p><b>Inhalation of grinding dust which is dangerous to the health.<br/>This can result in injury to the respiratory tract.<br/>Never blow out the grinding material residue, use suction instead.<br/>Wear breathing protection if necessary.</b></p> |

- ↓ Pre-clean the grinding chamber using a hand brush.
- ↓ Suck up the remaining grinding material residue using a suitable suction device.
- ↓ Remove clinging grinding material residue using a suitable wooden scraper.
- ↓ Close the housing flaps
- ↓ Machine can be started again



## **8.5 Replacing the gear box**

The gearbox is dimensioned so that a replacement is only necessary in exceptional cases. Dismounting and mounting of the gear box requires specialist knowledge and a careful working method. Therefore, please observe the instructions given in the installation manual of the gear box manufacturer or ask the ZERMA service department for help.

## **8.6 Replacing the rotor**

The rotor is a heavy duty design so that a replacement is only necessary after a crash, e.g. a hammer fall inside. Dismounting and mounting of the rotor requires specialist knowledge and a careful working method. Please ask ZERMA service department for help.

## **8.7 Replacing the main bearings**

The main bearings of the machine are dimensioned so that a bearing replacement is only necessary in exceptional cases. Dismounting and mounting of the bearings requires specialist knowledge and a careful working method. Therefore please ask the ZERMA service department for help.

## 8.8 Lubricating the main bearings

An important requirement for high operational safety and long service life of the arrangement of bearings is the correct lubricant supply. Every ZERMA machine is greased and checked in test runs before delivery.

### HINT



**Unsuitable lubricant, lubricant deficiency, excessive lubrication or impurities in the lubricant lead to overheating and thus extreme wear of the bearings.**

#### 8.8.1 Lubrication intervals:

| Shift operation        | Replace lubricant | Check   |
|------------------------|-------------------|---------|
| One shift operation:   | every 18 months   | monthly |
| Two shift operation:   | every 9 months    | monthly |
| Three shift operation: | every 6 months    | monthly |

#### 8.8.2 Check lubricant quality

You can judge whether the lubricant needs to be replaced by checking for the following features:

- change in consistency,
- discolouration,
- degree of soiling.

#### 8.8.3 Replacing or refilling lubricant

### HINT



- **Fill the bearings uniformly with grease, so that all operating surfaces are well greased.**
- **For the rotor bearings, a lubricant quantity of one third to a maximum of half of the bearing volume per bearing is required. If too much grease is filled in, the lubricant will become unusable as a result of excessive temperature.**
- **Only one type of grease may be used, mixing different types of grease is not allowed. The bearings have been filled at the factory with lithium base saponification roller bearing grease F3.**
- **To find out which lubricants from which manufacturers you can use, look in the *List of lubricants*.**

### **Refilling lubricant**

The grease reaches through the circulating grooves and bores via lubrication nipples into the interior of the bearing.  
The greasing quantity is 60 to 100 g roller bearing grease F3 per bearing.

Illustration:  
Grease nipple

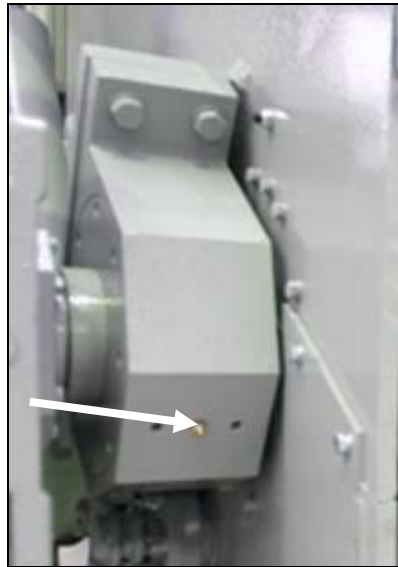

### **Replacing lubricant**

Only in the case of unusual bearing noises or overheating is it also necessary to renew the lubricant between the specified intervals. Mounting and dismounting of the bearings is to be carried out in accordance with the instructions in this operation manual (see replacing the bearings).

- ↓ Open the bearing.
- ↓ Remove the bearing housing and the bearing cover.
- ↓ Clean the bearing carefully using petroleum ether.  
Petroleum ether, petroleum, spirit, aqueous neutral or alkaline cleaning agents may be used to clean the bearings. After washing out, the bearing must immediately be preserved using lubricant, in order to avoid corrosion.
- ↓ Fill bearing with approved lubricant (see *List of lubricants*).

**8.8.4 List of lubricants**

| <b>Country of manufacture / manufacturer</b> | <b>Roller bearing grease</b>              |
|--|---|
| ARAL   | ARAL Grease HL 3                          |
| BP   | BP ENERGREASE LS 3                        |
| CASTROL                                      | CASTROL SPHEEROL AP 3                     |
| ESSO   | Beacon 3                                  |
| FUCHS  | FUCHS Grease 1200<br>FUCHS Grease FWA 220 |
| SHELL  | SHELL Alvania Grease 3                    |
| MOBIL-OIL                                    | MOBILUX 3                                 |
| WISURA                                       | WISURA Liba L 3                           |
| Zeller & Gmelin                              | ZET GE Grease M 50                        |
| FAG  | FAG L 71                                  |
| ANTAR Petroles de l'Atlantique               | ROLEXA                                    |
| Holland, Beverol                             | Beverol Multi Purpose Grease              |
| Italy, Agip                                  | AGIP Grease 33 FD                         |
| Swede, NYNÄS                                 | Nynäs FI 3-42                             |

## 8.9 Mounting and dismounting TAPER-LOCK tensioning element

The motor- and the gear-"V"-belt pulleys are attached onto the shaft by means of a TAPER-LOCK tensioning element. The disks must be dismantled for certain maintenance work.

**IMPORTANT:** Follow all instructions in this manual carefully. This is necessary to insure satisfactory performance.

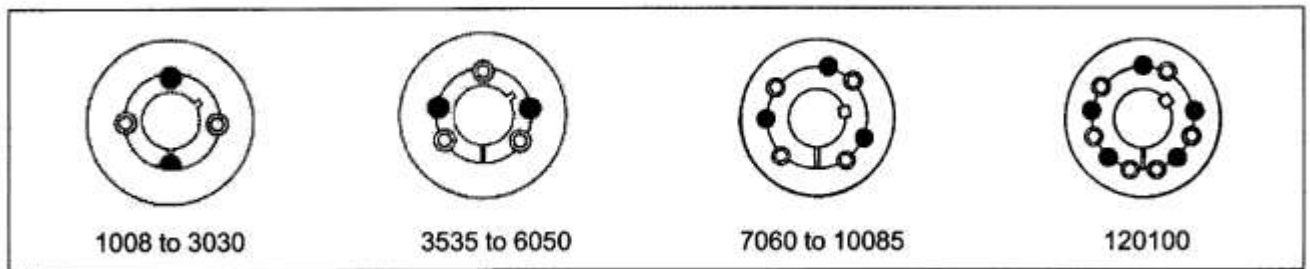

### To Install:

1. Clean shaft, bore, and outside of bushing, and bore of hub (taking bushing from hub if already assembled). Remove any oil, lacquer, or dirt. Place bushing in hub and match half holes to make complete holes (each complete hole will be threaded on one side only).
2. Oil thread and point of set screws or thread and under head of cap screws. Place screws loosely in holes that are threaded on hub side (shown thus  in diagram).
3. Make sure bushing is free in hub. Slip assembly onto shaft and locate in position desired.
4. Tighten screws (see note\*) alternately and evenly until all are pulled up very tightly. Use a piece of pipe on wrench to increase leverage. (See table for wrench torque on reverse side.)
5. Hammer against large end of bushing using hammer and block or sleeve to avoid damage. Screws can now be turned a little more using the specified wrench torque. Repeat this alternate hammering and screw re-tightening until the specified wrench torque no longer turns the screws after hammering.
6. After drive has been running under load for a short time stop and check tightness of screws. Fill other holes with grease to exclude dirt.

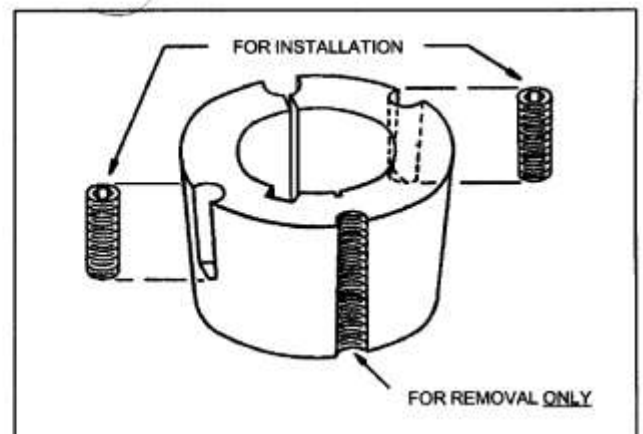

### To Remove:

1. Remove all screws. Oil thread and point of set screws or thread and under head of cap screws.
2. Insert screws in holds that are threaded on bushing side (shown thus  in diagram). In sizes where washers are found under screw heads, be sure to use these washers. Note that one screw in each hub is left over and is not used in this loosening operation.
3. Tighten screws alternately until bushing is loosened in hub. If bushing does not loosen immediately, tap on hub.

### 8.9.1 Table for the tightening torque of the screws

| Tensioning element (Type) | Screws-Tightening torque in Nm | Screw details |            |
|---------------------------|--------------------------------|---------------|------------|
|                           |                                | Number        | Size (BSW) |
| 3535                      | 60                             | 3             | 1/2"       |

### **8.9.2 Mounting the TAPER-LOCK tensioning element**

**Proceed as follows:**

- ↓ Remove the protective coating from the bore and outside of bushing, and bore of hub. After ensuring that the mating tapered surfaces are completely clean and free from oil or dirt. Insert bushing in hub so that holes line up.
- ↓ Sparingly oil thread and point of grub screws, or thread and under head on cap screws. Place screws loosely in holes threaded in hub, shown thus © in.
- ↓ Clean shaft and fit hub to shaft as one unit and locate in position desired, remembering that bushing will hip the shaft first and then will be slightly drawn on the bush.
- ↓ Using a hexagon wrench tighten screws gradually and alternately to certain torque.
- ↓ Hammer against large-end of bushing, using a block or sleeve to prevent damage. (This will ensure that the bushing is seated squarely in the bore). Screws will now turn a little more. Repeat this alternate hammering and screw tightening once or twice to achieve maximum grip on the shaft.
- ↓ If a key is to be fitted, place it in the shaft keyway before fitting the bushing. It is essential that it is a parallel key and side fitting only and has TOP CLEARANCE.
- ↓ After drive has been running under load for a short time stop and check tightness of screws.
- ↓ Fill empty holes with grease to exclude dirt.

### **8.9.3 Dismounting the TAPER-LOCK tensioning element**

**Proceed as follows:**

- ↓ Slacken all screws by several turns, remove one or two according to number of jacking off holes shown thus • in the illustration. Insert screws in jacking off holes after oiling thread and point of grub screws or thread and under head of cap screws.
- ↓ Tighten screws alternately until bushing is loosened in hub and assembly is free on the shaft.
- ↓ Remove assembly from shaft.

## 8.10 Work on the "V"-belts

"V"-belts are wearing parts, which stretch and must be retensioned. In order to guarantee a long service life of the "V"-belts, regular checks on the tension force of the "V"-belts and the condition of the "V"-belts are necessary.

### 8.10.1 Checking the tension force of the "V"-belt

Illustration:

a: Distance between roller centres  
b: Sag  
F: Force(direction)

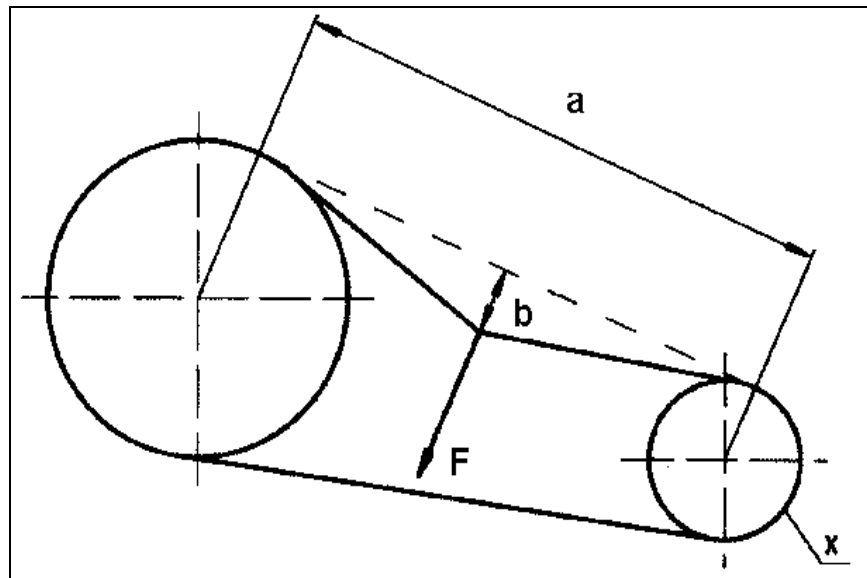

- ↓ Remove the "V"-belt cover.
- ↓ Measure the distance between the roller centres.
- ↓ Determine the belt sag force F for each belt at 16 mm sag if sag "b" is equal to 1 m distance between roller centres. Do this by measuring at the middle of the distance between roller centres at a right angle to the "V"-belt.

|                        |                              | <b>Force required for 1 m distance between roller centres and 16 mm sag</b> |                 |
|------------------------|------------------------------|---|-----------------|
| <b>Profile section</b> | <b>Efficiency of x in mm</b> | <b>P in Newton</b>  | <b>P in lbs</b> |
| SPC                    | 224 - 355                    | 60 - 90   | 13,2 - 19,8     |
| SPC                    | 375 - 560                    | 90 - 120  | 19,8 - 26,4     |

- ↓ Compare determined value with the value in the above table. If the value lies below the lowest tolerance limit, the "V"-belt must be retensioned. If the value lies above the highest tolerance limit, the "V"-belt must be relaxed.



### 8.10.2 Retensioning and relaxing the "V"-belt

Enlarging or decreasing the centre distance "A" into which the drive motor is shifted carries out tensioning or relaxing the "V" - belt.

**Proceed as follows:**

- ↓ Loosen the tensioning screw.
- ↓ Shift the drive motor as required onto the sliding rails.
- ↓ Lock the drive motor into new position using both tensioning screws in such a way that the motor shaft is parallel to the rotor axis and aligned.
- ↓ Check the tension force of the "V"-belt (see *Checking the tension force of the "V"-belt*).
- ↓ Mount the "V"-belt cover.

### 8.10.3 Checking "V"-belt condition, replacing "V"-belt

|  |  |
|--|--|
|  <b>CAUTION</b> |  |
|                 | <p><b>Danger of pulling into machine caused by running "V"-belts.</b><br/><b>Hair, jewellery etc. can be pulled into the machine. Serious injury can result.</b><br/><b>Never dismount the "V"-belt cover and window during operation.</b></p> |

If a "V"-belt is porous or ripped, it must be replaced as follows:

- ↓ Remove the "V"-belt cover.
- ↓ Loosen the front and rear tensioning screw.
- ↓ Relax the "V"-belt by shifting the drive motor.
- ↓ Put new "V"-belt in.
- ↓ Tension the "V"-belt
- ↓ Mount the "V"-belt cover.



## 8.11 Working on the cutting knives

In the case of shredders, the correct grinding properties, correct setting and mounting of the cutting knives are important factors to ensure perfect functioning and economic operation of the machine.

### 8.11.1 Replacing and checking the cutting knife mountings

↓ Due to their function, certain machine parts are subject to stress in their operating state as a result of vibrations, which can lead to loosening of the screw connections. Therefore, it is absolutely necessary to check the cutting knife mounting screws in accordance with the maintenance plan.

↓ Tighten the mounting screws on the cutting knives using a torque wrench which is set to the required torque for the screw size.

**The required torque for the knife fixing bolts is 120 Nm.**



You can find out the required torque from the following table. Take note too that the tightening capacity decreases of screws which have been loosened and tightened again several times.

New screws of the same material quality must therefore replace the cutting knife mounting screws after they have been loosened and tightened several times.

#### **Torque:**

| Bolt type | Grade 8.8 |        | Grade 10.9 |        | Grade 12.9 |        |
|-----------|-----------|--------|------------|--------|------------|--------|
|           | Nm        | lbf ft | Nm         | lbf ft | Nm         | lbf ft |
| M8        | 25        | 18.4   | 35         | 25.8   | 41         | 30.2   |
| M10       | 49        | 36.1   | 69         | 50.9   | 83         | 61.2   |
| M12       | 86        | 63.4   | 120        | 88.5   | 145        | 106    |
| M16       | 210       | 154    | 295        | 217    | 355        | 261    |
| M20       | 410       | 302    | 580        | 428    | 690        | 508    |
| M24       | 710       | 523    | 1000       | 737    | 1200       | 885    |

### 8.11.2 Checking the condition of the cutting knives



|  |  |
|--|--|
|  <b>WARNING</b> |  |
|                 | <p><b>Danger of cutting caused by sharp knives, even when the rotor is at a standstill.<br/>Serious injury, particularly to hands and fingers, can result.<br/>Wear protective gloves.</b></p> |

The cutting knives become blunt after a certain number of operation hours. Therefore they should be checked regularly.

**Using blunt knives has the following consequences:**

- Decreased grinding capacity.
- Increased current consumption of the drive motor.
- Inexact cut.
- Overheating of the ground material.

### 8.11.3 Dismounting the rotor knives

|  |   |
|--|---|
|  <b>WARNING</b> |   |
|                 | <b>Danger of cutting caused by sharp knives, even when the rotor is at a standstill.</b><br><b>Serious injury, particularly to hands and fingers, can result.</b><br><b>Wear protective gloves.</b> |

#### Proceed as follows:

Illustration:

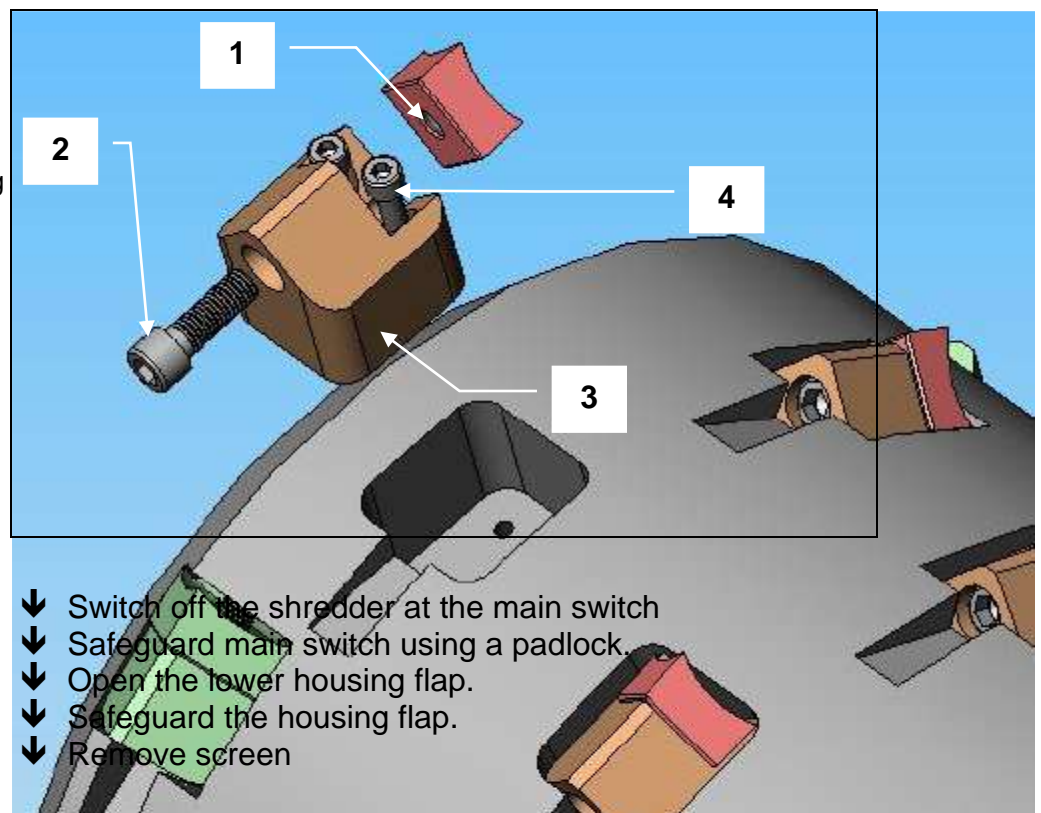

- (1) Rotor knife
- (2) Knife mounting screw
- (3) Knife holder
- (4) Knife holder mounting screws



Although it is possible to reach the cutting shaft by climbing into the feeding chamber, we recommend accessing the knives through the front side door. The shaft can be rotated manually by turning the motor v-belt pulley.

- - ↓ Clean the hexagon head socket of the knife fixing bolt (2).
  - ↓ Loose the bolt using a high quality Allen key (10 mm). If necessary knock the Allen key lightly with a hammer to loose it.
  - ↓ Take out the knife fixing bolt, the washer and the knife

### 8.11.4 Dismounting the rotor knife holders

|  |  |
|--|--|
|  <b>WARNING</b> |  |
|                 | <p><b>Danger of cutting caused by sharp knives, even when the rotor is at a standstill.</b><br/><b>Serious injury, particularly to hands and fingers, can result.</b><br/><b>Wear protective gloves.</b></p> |

**Proceed as follows:**

Illustration:

- (1) Rotor knife
- (2) Knife mounting screw
- (3) Knife holder
- (4) Knife holder mounting screws

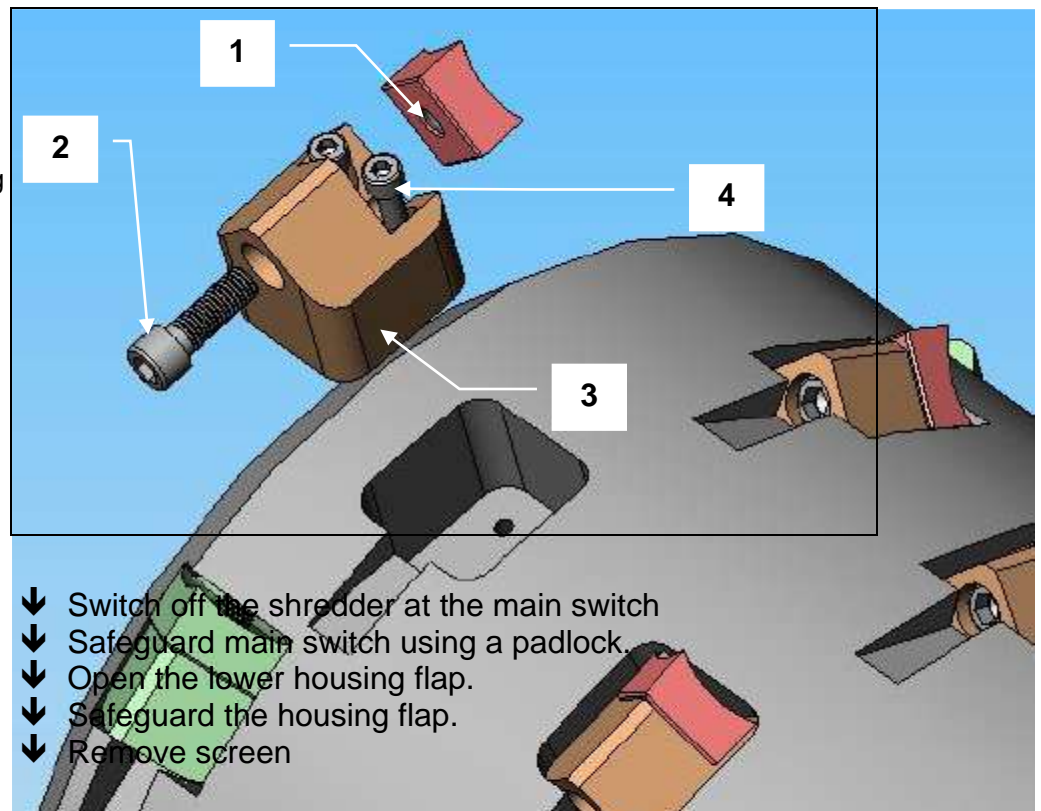

Although it is possible to reach the cutting shaft by climbing into the feeding chamber, we recommend accessing the knives through the front side door. The shaft can be rotated manually by turning the motor v-belt pulley.

- - ↓ Clean the hexagon head socket of the knife fixing bolt (2).
  - ↓ Loose the bolt using a high quality Allen key (10 mm). If necessary knock the Allen key lightly with a hammer to loose it.
  - ↓ Take out the knife fixing bolt, the washer and the knife
  - ↓ Clean the hexagon head socket of the knife holder fixing bolts (4).
  - ↓ Loose the bolt using a high quality Allen key (6 mm). If necessary knock the Allen key lightly with a hammer to loose it.
  - ↓ Take out the knife holder fixing bolts.
  - ↓ Remove the knife holder with the delivered Extractor.



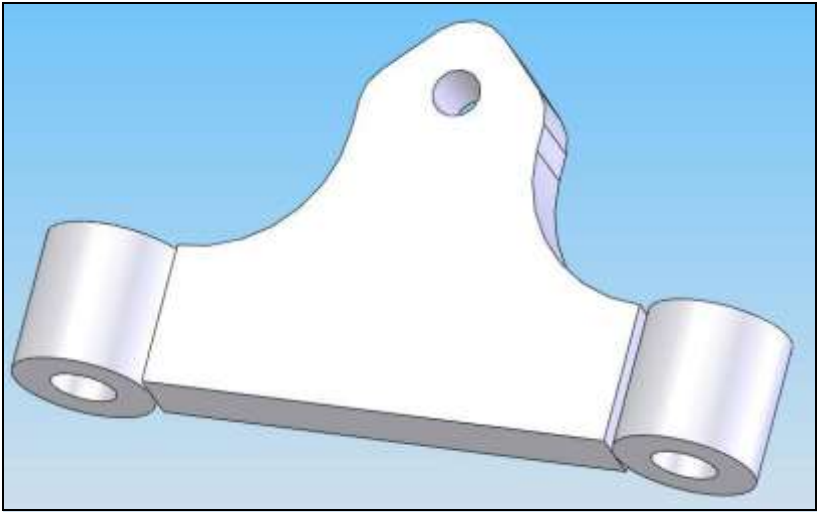

Illustration:

Knife holder extractor



### 8.11.5 Dismounting the stator knives

|  |  |
|--|--|
|  <b>WARNING</b> |  |
|                 | <p><b>Danger of cutting caused by sharp knives, even when the rotor is at a standstill.</b><br/><b>Serious injury, particularly to hands and fingers, can result.</b><br/><b>Wear protective gloves.</b></p> |

#### Proceed as follows:

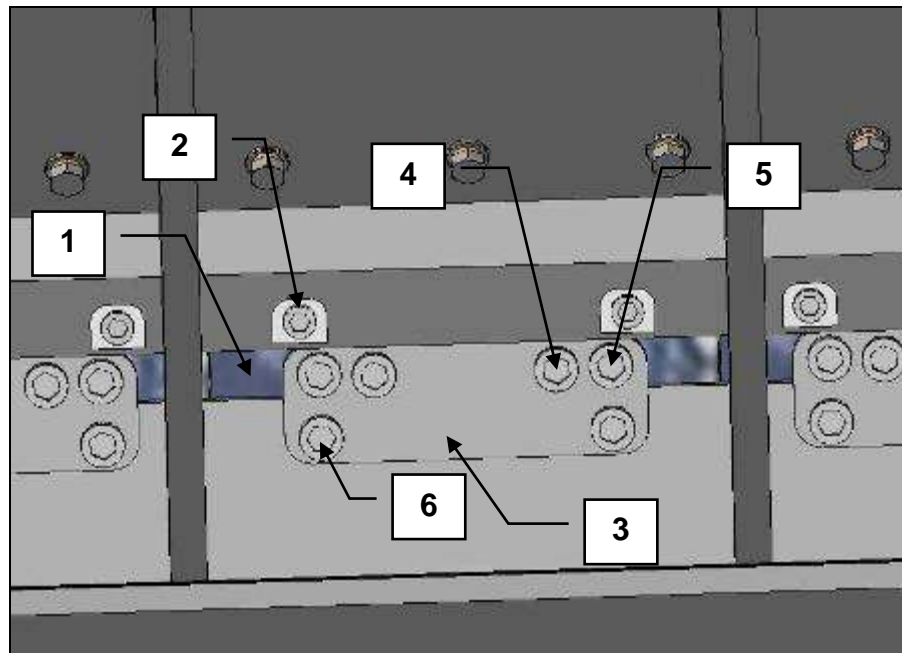

Illustration:

- (1) Stator knife
- (2) Knife fixing screws
- (3) Knife holder
- (4) Knife adjusting screw for pushing
- (5) Knife adjusting screw for pulling
- (6) Knife holder fixing screws



- ↓ Switch off the shredder at the main switch
- ↓ Safeguard main switch using a padlock.
- ↓ Open the feeding trough cover.
- ↓ Safeguard the cover.
- ↓ Clean the hexagon head socket of the knife fixing bolts (2) and the knife holder plates fixing bolts.
- ↓ Loose the knife fixing bolts using a high quality Allen key (10 mm). If necessary knock the Allen key lightly with a hammer to loose it. Do not take out the bolts.
- ↓ Loose the knife holder fixing screws and take them out.
- ↓ Take out the knife and the knife holder fixing plate together.

### 8.11.6 Mounting the rotor knife holders

|  |  |
|--|--|
|  <b>WARNING</b> |  |
|                 | <p><b>Danger of cutting caused by sharp knives, even when the rotor is at a standstill.</b><br/><b>Serious injury, particularly to hands and fingers, can result.</b><br/><b>Wear protective gloves.</b></p> |

**Proceed as follows:**



- ↓ Clean the knife pocket and the knife holder
- ↓ Insert knife holder into the pocket

**Knife holder must slide in easily. Do not damage the knife holder surfaces using a steel hammer. Use a rubber hammer.**

- ↓ Put in the knife holder fixing bolts (DIN 912 – M8x25 – 12.9) and put some Loctite on them.
- ↓ **Make sure that the knife holder fits properly.**
- ↓ Tighten the knife fixing bolts using a torque wrench.

**The required torque for the knife holder mounting bolts is 41 Nm (also see the table under *Replacing and checking the cutting knife mountings*).**

### 8.11.7 Mounting the rotor knives

|  |  |
|--|--|
|  <b>WARNING</b> |  |
|                 | <p><b>Danger of cutting caused by sharp knives, even when the rotor is at a standstill.</b><br/><b>Serious injury, particularly to hands and fingers, can result.</b><br/><b>Wear protective gloves.</b></p> |

### HINT



The cutting knives, in particular the rotor knives, should only be sharpened or replaced in sets. There is a danger of balance error if a combination of rotor knives from different knife sets is used.

#### Proceed as follows:

- ↓ Clean the knife supporting surface and the hole on the knife holder
- ↓ Insert sharp knife or turn old knife and push against the knife holder surface.
- ↓ Put in the knife fixing bolt (DIN 912 – M12x40 – 12.9) and the washer (DIN433 – 13 – 300HV).
- ↓ Screw in the mounting screw and tighten lightly first
- ↓ **Make sure that the knife fits planar in the seat**
- ↓ Tighten the knife fixing bolt using a torque wrench.

**The required torque for all knife mounting bolts is 120 Nm** (also see the table under *Replacing and checking the cutting knife mountings*).

- ↓ **Check whether the cutting gap is correct and whether the cutting knives do not collide as the rotor turns.**



### TIP



Rotor knives from ZERMA are reversible and have four symmetrical cutting edges.  
This makes it possible to turn the knives and only to sharpen after every fourth knife change.

- ↓ Remove tools and other objects from the cutting chamber.
- ↓ Switch on the shredder for a short time without grinding material and listen for noises. If you hear unusual noises, determine the cause and eliminate it.

### 8.11.8 Mounting and adjusting of the stator knives

|  |   |
|--|---|
|  <b>WARNING</b> |   |
|                 | <b>Danger of cutting caused by sharp knives, even when the rotor is at a standstill.<br/>Serious injury, particularly to hands and fingers, can result.<br/>Wear protective gloves.</b> |

Rotor knives for the ZRS series shredder don't have to be adjusted. All adjustments have to be done with the stator knives. To simplify knife setting and shorten standstill periods when replacing the knives, Zerma stator knives have four adjusting screws, two for pulling two for pushing the knife. If you have several knife sets, you will also avoid standstill periods of the machine. Correct and careful setting of the gap between the rotor knives and the stator knives (cutting gap) is an important requirement for the productive capacity of the shredder.

#### **Proceed as follows:**

↓ Open the communication hole

Illustration:

- (1) Communication hole
- (2) Cover plate
- (3) Fixing screws

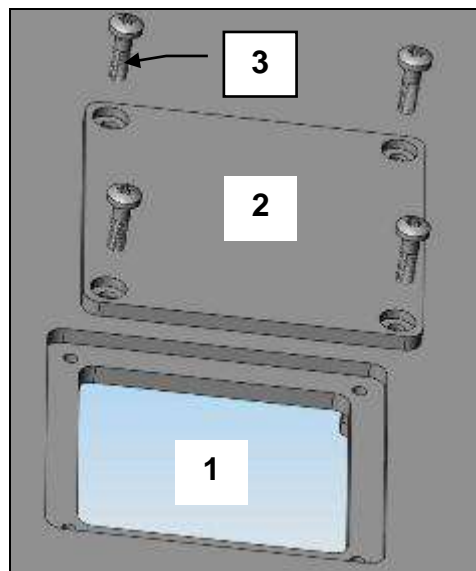

- ↓ Clean the knife supporting surface and the holes on the knife holder
- ↓ Insert sharp knife or turn old knife.
- ↓ Put in the knife adjusting bolts for pushing and adjust them roughly
- ↓ Put in the knife adjusting bolts for pulling and tighten lightly first
  
- ↓ **Adjust the gap between rotor and stator knife to 0.8-1.0 mm by using the adjusting bolts.**

- ↓ Tighten constant both knife adjusting bolts for pulling by using a torque wrench.
- ↓ Tighten constant both knife fixing bolts by using a torque wrench.

**The required torque for all knife mounting bolts M12 is 120Nm**  
**The required torque for all knife adjusting bolts for pulling M16 is 120Nm**

(also see the table under *Replacing and checking the cutting knife mountings*).

Illustration:

- (1) Stator knife
- (2) Knife fixing screws
- (3) Knife holder
- (4) Knife adjusting screw for pushing
- (5) Knife adjusting screw for pulling
- (6) Knife holder fixing screws

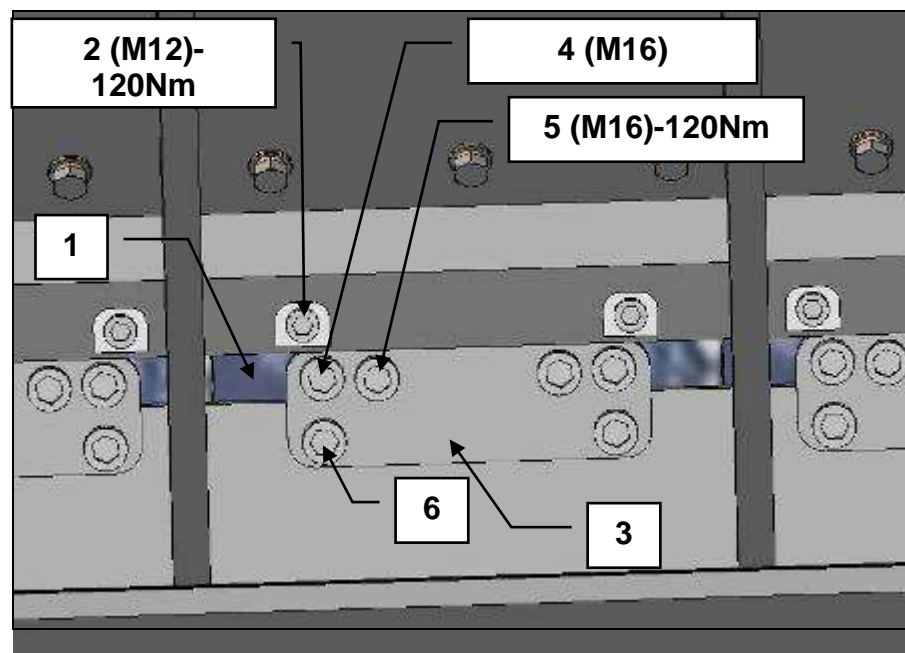

- ↓ Turn the rotor by hand
- ↓ **Check whether the cutting gap is correct and whether the cutting knives do not collide as the rotor turns.**



## TIP

**Stator knives from ZERMA are reversible and have two symmetrical cutting edges.**  
**This makes it possible to turn the knives and only to sharpen after every second knife change.**

- ↓ Put back the cover plate of the communication hole and fix them with the bolts.
- ↓ Remove tools and other objects from the cutting chamber.
- ↓ Switch on the shredder for a short time without grinding material and listen for noises. If you hear unusual noises, determine the cause and eliminate it.



### 8.11.9 Sharpening cutting knives

Shredder rotor knives from ZERMA have four cutting edges. This means they can be turned three times. After that they should be replaced with new ones. Stator knives can be turned two times and can be resharpened as long as you can fix them with the long hole.

## TIP



**Specialist sharpening of the cutting knives is part of the service offer of ZERMA.**

|  |   |
|--|---|
|  <b>WARNING</b> |   |
|                | <b>Danger of cutting caused by sharp knives, even when the rotor is at a standstill.<br/>Serious injury, particularly to hands and fingers, can result.<br/>Wear protective gloves.</b> |

## HINT





**The cutting knives, in particular the rotor knives, should only be sharpened or replaced in sets. There is a danger of balance error if a combination of rotor knives from different knife sets is used.**

### Proceed as follows:

- ↓ Dismount the cutting knives (see dismantling the knives)
- ↓ Sharpen the cutting knives.
- ↓ A specialist in accordance with the sharpening plan using particular care should uniformly sharpen the cutting knives mechanically. It is important to make sure that sharpening takes place with small grinding allowance and sufficient coolant supply. The sharpening process is finished when the cutting edge is sharply cut. Not all indentations must be ground off; otherwise the number of possibilities for sharpening is unnecessarily reduced.
- ↓ For the sharpening process, use soft grinding wheels (Quality 40 H or 46 K). Knives, which have grinding cracks, are not to be reused due to danger of breakage during operation.
- ↓ Whet the cutting edges of the cutting knives using a whetstone.
- ↓ By taking these measures, the service life of the cutting knives can be increased.
- ↓ Set the cutting knives (see *setting the cutting knives*).
- ↓ Mount the cutting knives (see *mounting the stator knives*).

**8.11.10 Transporting and storing the cutting knives**

|  <b>WARNING</b> |   |
|--|---|
|                 | <p><b>Danger of cutting caused by sharp cutting knives. Serious injury, in particular to hands and fingers, can result. Wear protective gloves.</b></p> <p><b>Only transport and store the cutting knives packaged. Grease the cutting knives well, so that they do not rust. Protect the cutting edges with doubled cardboard and use adhesive tape to safeguard the knives against slipping out of the sides of the sheath.</b></p> <p><b>After unpacking, you must degrease the cutting knives so that they can be gripped safely.</b></p> |

## **9 TROUBLESHOOTING**

### **9.1 Machine blocks or switches itself off**

| <b>No.</b> | <b>Possible causes</b>         | <b>Remedy required</b>  |
|------------|--------------------------------|---|
| 9.1.1      | Too much feed material.        | Reduce grinding material in feed.   |
| 9.1.2      | Pusher blocked.                | Check hydraulic system and distance sensor  |
| 9.1.3      | "V"-belts slip.                | Check "V"-belt tension and condition and retighten if necessary or replace.                                     |
| 9.1.4      | Knife condition.               | Check knives and sharpen or replace if needed.  |
| 9.1.5      | Cutting gap.                   | Check cutting gap and set according to the instructions in this operation manual.                               |
| 9.1.6      | Discharge blocked.             | Check if discharge conveyor belt is running   |
| 9.1.7      | Current failure.               | Check limit switch for defective contact.<br>Check electrical connection,<br>if necessary tighten limit switch. |
| 9.1.8      | Fuse too small.                | Fit larger fuse. <b>Only after consulting the service department of ZERMA.</b>                                  |
| 9.1.9      | Rotational direction of rotor. | Check motor and reverse polarity if necessary.  |
| 9.1.10     | Rotor speed.                   | Change rotor speed. <b>Only after consulting the service department of ZERMA.</b>                               |

### **9.2 Rotor does not grip bulky material**

| <b>No.</b> | <b>Possible causes</b>       | <b>Remedy required</b>  |
|------------|------------------------------|---|
| 9.2.1      | Knife condition.             | Check and sharpen if needed according to the instructions in this operation manual. |
| 9.2.2      | Protruding bed knife.        | Chamfer bed knives; consult with service department of ZERMA.                       |
| 9.2.3      | Knives not aggressive enough | Fit underlay plates below the knife holders   |
|            |                              |   |

### **9.3 Overheating of the grinding material**

| <b>No.</b> | <b>Possible causes</b>                  | <b>Remedy required</b>   |
|------------|---|--|
| 9.3.1      | See 9.1.1 to 9.1.5.                     | See 9.1.1 to 9.1.5.  |
| 9.3.2      | Knives wrongly sharpened.               | Modify knife finish. <b>Only after consulting the service department of ZERMA.</b> |
| 9.3.3      | Material rubs against the housing wall. | Fit anti-winding device.   |
| 9.3.4      | Insufficient cooling.                   | Fit rotor cooling  |

### **9.4 Unusual vibrations**

| <b>No.</b> | <b>Possible causes</b>        | <b>Remedy required</b>                            |
|------------|-------------------------------|---|
| 9.4.1      | Rotor out of balance.         | Weigh knives, balance rotor.                      |
| 9.4.2      | Bearing damage.               | Check bearings, replace bearings if necessary.    |
| 9.4.3      | Anti vibration pads defective | Check mounting pads and renew these if necessary. |

## 9.5 Extreme cutter wear

| No.   | Possible causes    | Remedy required   |
|-------|--------------------|---|
| 9.5.1 | Bearing damage.    | Check bearings, replace bearings if necessary.                                    |
| 9.5.2 | Knife finish.      | Check knife and sharpen or replace if necessary.                                  |
| 9.5.3 | Wrong cutting gap. | Check cutting gap and set according to the instructions in this operation manual. |
| 9.5.4 | Foreign matter.    | Check the material carefully  |

## 9.6 Bearings too hot

| No.   | Possible causes                  | Remedy required                       |
|-------|----------------------------------|---------------------------------------|
| 9.6.1 | Too much grease in bearing.      | Reduce amount of grease.              |
| 9.6.2 | "V"-belts too tight.             | Reduce tension.                       |
| 9.6.3 | Rubbing on housing sealing ring. | Check sealing ring, oil or replace.   |
| 9.6.4 | Bearing damage.                  | Check bearings, replace if necessary. |
| 9.6.5 | No grease in bearing.            | Lubricate bearing.                    |

## 9.7 Cutting gap alters during operation

| No.   | Possible causes                  | Remedy required   |
|-------|----------------------------------|---|
| 9.7.1 | Knife mounting screws not tight. | Retighten using torque wrench in accordance with table in operation manual. |
| 9.7.2 | Screw fatigue.                   | Fit new screws.   |
| 9.7.3 | Washers deformed.                | Insert new washers.   |
| 9.7.4 | Knife holder surface deformed    | Insert new knife holders  |
| 9.7.5 | Supporting surfaces not clean.   | Clean and de-rust supporting surfaces.                                      |
| 9.7.6 | Threads in housing worn.         | Fit new bushes in housing.  |

## 9.8 Shredder does not start

| No.   | Possible causes                  | Remedy required  |
|-------|----------------------------------|--|
| 9.8.1 | Limit switches not activated.    | Check position of limit switch and correct.                      |
| 9.8.2 | Main and control fuses.          | Replace fuse.  |
| 9.8.3 | Cover not fully opened           | Check position of proximity switch and correct.                  |
| 9.8.4 | Manual mode instead of automatic | Switch from manual to automatic mode                             |
| 9.8.5 | Star delta connection.           | Correct wiring on motor.   |
| 9.8.6 | Motor protection switches off.   | Check motor relay for correct setting and increase if necessary. |
| 9.8.7 | Star delta time relay.           | Correct time.  |

## 9.9 Shredder blocks when under load

| No.    | Possible causes                          | Remedy required  |
|--------|--|--|
| 9.11.1 | Feed starts too early.                   | Start feed only after switch over from star to delta.  |
| 9.11.2 | Limit switch loose or wrongly set.       | Reposition and tighten limit switch.   |
| 9.11.3 | Fuse defective.                          | Replace fuse.<br>Fit larger fuse. <b>Only after consulting the service department of ZERMA GmbH.</b> |
| 9.11.4 | Motor fuse switches off - red indicator. | Reduce feed quantity of the grinding material, correct setting, replace fuse.                        |

## **10 STORAGE, DISPOSAL, TRANSPORTATION**

### **10.1 Storage**



Clean the machine (see Cleaning the machine). Preserve all polished metal surfaces using a suitable rust preventing agent. Store the machine in an enclosed, dry place. Cover the machine completely with a plastic sheet.



### **10.2 Disposal**



**Protect the environment.**

The disposal of machines, machine components and process materials is partially subject to legal controls. More detailed information is given at the relevant administrative authority (e.g. regional and national Water Conservation Bureaux and Environmental Protection Agencies). Only deposit the material to be disposed of at authorized drop-off points.

### **10.3 Transportation**

|  <b>WARNING</b> |   |
|--|---|
|                 | <p><b>Suspended load.</b><br/>Falling loads can cause serious injury or death.<br/>Only use a crane or forklift truck, which is suitable for the weight and dimensions of the loads.</p>                    |
|                 | <p>Also use suitable stopping means and pay attention to the gravity centre location.<br/>Do not step under the suspended load.<br/>Wear a protective helmet in addition to your basic protective gear.</p> |

## **11 HYDRAULIC MAINTENANCE**

Before start-up of the machine, hydraulic oil has to be filled into the tank. Capacity of the tank is 800 l.

The type of oil which should be used depends on your location.

We recommend oil of the type DIN 51524 HLP 32 or 46.

The first oil replacement should be done after 750 operating hours and then after every 1500 operating hours. The oil filter has to be replaced too when changing the oil.

If the warning lamp of the oil filter is alighted the oil and the filter have to be replaced earlier.

### **HINT**



**If the oil will not be replaced after this time damage to the hydraulic system can occur, due to overheating of the oil and dirt in the oil. This can lead to a complete standstill of the machine.**

When adding hydraulic oil, attention must be paid that the same type of oil is used. If the same type of oil is not available, or if the type used is unknown, the oil in the tank and in the complete hydraulic system has to be removed and the complete system flushed carefully. The system may only be filled with new oil after this has been done. This is necessary to prevent gumming of the valves.

**Hydraulic liquid recommendation:**

|                           |   |
|---------------------------|---|
| Designation to DIN 51 524 | HLP 32  |
| Ambient temperature:      | -7 to +70°C   |
| Supplier                  | Name of the oil   |
| ARAL                      | Aral Vitam GF 32<br>Aral Vitam HF 32                                      |
| BP                        | BP Energol HLP-D 32<br>BP Energol HLP 32<br>BP Energol SHF 32             |
| ELF                       | Elfina 32<br>Hydrelf 32   |
| ESSO                      | Nuto H 32<br>HLPD-Oel 32  |
| FINA                      | Fina Hydran 32  |
| FUCHS                     | Renolin MR 10<br>Renolin B 10   |
| MOBIL                     | Mobil DTE 24<br>Mobil DTE 17<br>Drucköl HLP 32 - C<br>Hydrauliköl HLPD 32 |
| TEXACO                    | Rando Oil HD A - 32<br>Rando Oil HD AZ - 32<br>Alcor Oil DD 32            |



## **11.1 Hydraulic set up**

1. Connect hydraulic pipes to the machine; ensure that the upper hydraulic pipe is connected to the upper pipe at the machine.
2. Connect the wires for the motor and magnetic valves.
3. Connect water supply to the oil cooling system.
4. Fill in the oil tank hydraulic oil No 68 till the maximum. Mark which level gauge (No.5) indicates.
5. Run motor to see whether the running direction is correct (face to the motor blade, motor running clockwise); if it is not correct, change position of two of the three electrical wires.
6. Run motor, operate the magnetic valve by first pushing the relieve valve (No.4), check if they work correctly and the wiring connections are right.
7. Start hydraulic unit and adjust the system pressure to 90-100 bar at the adjustment point (No.7) you can see the right adjustment on the pressure gauge(No.6)
8. Run the ZRS with loading and adjust the pressure gauge (No.1) to 25-30 bar with the pressure adjustment screw (No.2).  
**The optimal oil temperature is approx. 45° C**
9. By alighting of a warning lamp on the control panel the filter (No.8) has to be replaced.
10. Check the oil level at the level indicator frequently.

**Remarks: the oil must be changed the first time after 750 working hours after that every 1500 working hours.**

## 11.2 Trouble shooting

| <b>Trouble</b>                | <b>Cause</b>  | <b>Remedy</b>   |
|-------------------------------|---|---|
| 1. Motor doesn't work         | <ol style="list-style-type: none"> <li>1. Electric source</li> <li>2. Motor damage</li> </ol>   | <ol style="list-style-type: none"> <li>1. Correct wire connection</li> <li>2. Replace motor.</li> </ol>   |
| 2. Oil pump doesn't work      | <ol style="list-style-type: none"> <li>1. Motor not work</li> <li>2. Pump damage</li> </ol>   | <ol style="list-style-type: none"> <li>1. Correct wire connection</li> <li>2. Replace pump</li> </ol>   |
| 3. Oil pump noise             | <ol style="list-style-type: none"> <li>1. Filter jam</li> <li>2. Hydraulic oil too thick</li> <li>3. Hydraulic oil quality not good</li> <li>4. Pipe leaking</li> <li>5. Pump damage</li> <li>6. Motor and pump misalignment</li> </ol> | <ol style="list-style-type: none"> <li>1. Clean the filter</li> <li>2. Change hydraulic oil</li> <li>3. Change hydraulic oil</li> <li>4. Tighten pipe connectors</li> <li>5. Change pump</li> </ol>                         |
| 4. Working pressure abnormal  | <ol style="list-style-type: none"> <li>1. spillover valve and sequence valve jam</li> <li>2. pump damage</li> </ol>   | <ol style="list-style-type: none"> <li>1. Clean spill over valve and sequence valve</li> <li>2. Change pump</li> </ol>  |
| 5. Pressure maintain abnormal | <ol style="list-style-type: none"> <li>1. sealing broken</li> <li>2. pipe leak</li> <li>3. 3. Single direction valve jam</li> </ol>   | <ol style="list-style-type: none"> <li>1. Change sealing</li> <li>2. Check and solve the leak</li> <li>3. Clean the valve</li> </ol>  |
| 6. Work abnormal              | <ol style="list-style-type: none"> <li>1. Pressure abnormal</li> <li>2. Magnetic valve abnormal</li> <li>3. Electrical problem</li> </ol>   | <ol style="list-style-type: none"> <li>1. Clean spill over valve and sequence valve</li> <li>2. If the valve jams, clean it. If it is broken, change it</li> <li>3. Check and change the broken electrical parts</li> </ol> |

## 12 CUSTOMER SERVICE AND SPARE PARTS ORDERS



Should problems occur during operation of the machine or if you have general questions about the machine which this operation manual cannot answer, please do not hesitate to contact us. We would be pleased to help you further in order to solve your problem as quickly as possible.

You can identify the spare parts you require using the spare parts list. Please quote the following information when making your order so that we can deliver the spare parts to you quickly:

- Company name and address.
- Contact person.
- Machine type.
- Machine number.
- Piece number of the spare part.
- Spare part reference.
- Subject number.
- Order quantity.

### ZERMA AMERICA

**9120 Centerlinks Commerce Drive Unit 4  
Fort Myers, FL 33912**

**1-293-219-1800**

E-Mail: [Parts@zerma-america.com](mailto:Parts@zerma-america.com)  
Internet: <http://www.zerma-america.com>



### TIP

The easiest way to order your spare parts is to copy the spare parts list and to fill in the order amount after the respective spare part.



---

## **13 SPARE PARTS**

**Please refer to the machines “Packing list” delivered**

## 14 HYDRAULIC UNIT SHC-412 F ZRS1000-2000

### 14.1 Hydraulic Diagram

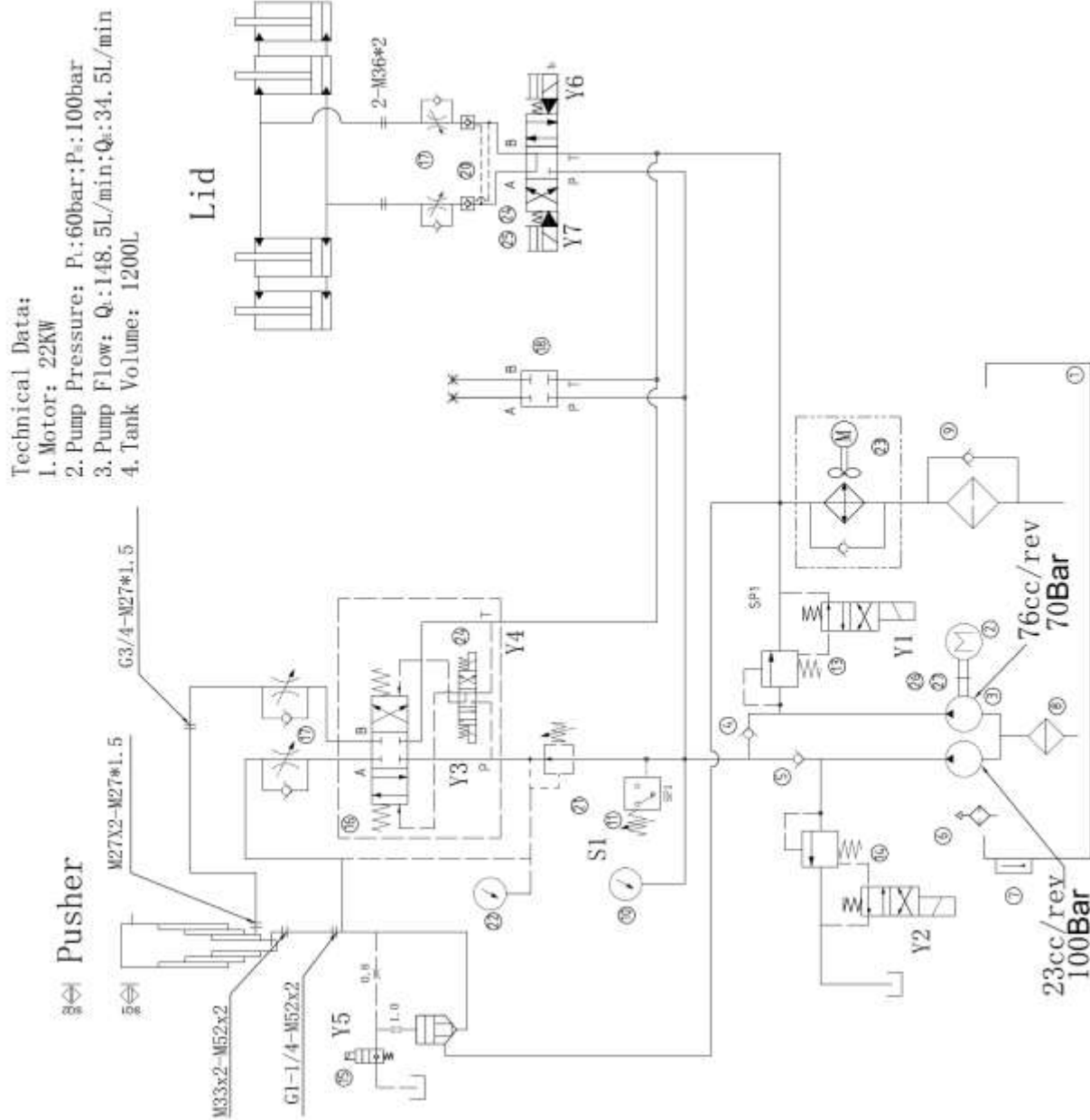

## 14.2 Spare parts list hydraulic unit

| No. | Discription              | Standard                | Pc |
|-----|--------------------------|-------------------------|----|
| 1   | TANK 1200L               | SHC-413-02              | 1  |
| 2   | ELECTRIC MOTOR           | 22KW-4P/B35             | 1  |
| 3   | VARIABLE VANE PUMP       | PVL13-23-76-F-1R-UU-10  | 1  |
| 4   | CHECK SWITCH             | CRG-06-1-10             | 1  |
| 5   | CHECK SWITCH             | CRG-03-1-10             | 1  |
| 6   | FILLER BREATHER          | AB-1163-ST              | 1  |
| 7   | FLUID LEVEL              | LG-300                  | 1  |
| 8   | SUCTION FILTER           | MF-16                   | 1  |
| 9   | RETURN FILTER            | RFA-630-10F CY-I        | 1  |
| 10  | PRESSURE GAGE            | 2.5"LA 0-25MPA G1/4     | 1  |
| 11  | PRESSURE GAGE            | PS-02-3-10              | 1  |
|     |                          |                         |    |
| 13  | SOLENOID DRECTION VALVE  | DSD-G02-22AL-DC24-82-ZD | 1  |
| 13  | SOLENOID RELIEF VALVE    | DBW-10-2-10             | 1  |
| 14  | SOLENOID DRECTION VALVE  | DSD-G02-2A-DC24-82-ZD   | 1  |
| 14  | SOLENOID RELIEF VALVE    | BSG-03-3-10             | 1  |
| 15  | LOGIC VALVE              | LCV-25-D-20             | 1  |
| 16  | SOLENOID DRECTION VALVE  | DG07-2C-T-10            | 1  |
| 17  | THYROTTE AND CHECK VALVE | MTC-04-W-O-20           | 2  |
| 18  | COVER PLATE              | MFC-02-10               | 1  |
| 19  | OIL WAY BLOCK            | MFB-412P-01             | 1  |
| 20  | PILOT CHECK VALVE        | MPD-04-W-1-10           | 1  |
| 21  | PRESSURE REDUCTION VALVE | MGV-04-A-2-20           | 1  |
| 22  | PRESSURE GAGE            | 2.5"LA 0-15MPA G1/4     | 1  |
| 23  | AIR COOLER 2.2KW         | DXB8A35MCX              | 1  |
| 24  | SOLENOID DRECTION VALVE  | DSD-G02-6C-DC24-82-ZD   | 2  |
| 25  | SOLENOID DRECTION VALVE  | DG07-6C-T-10            | 1  |
| 26  | BELL JAR                 | PK350(250-127-230)      | 1  |
| 27  | COUPLING                 | ML5-YA48*110/YA31.75*60 | 1  |
| 28  | OIL WAY BLOCK            | MFB-412E-02             | 1  |
| 29  | OIL WAY BLOCK            | YBK-04-01G              | 1  |
| 30  | OIL WAY BLOCK            | SHC-412E-05             | 1  |
| 31  | OIL WAY BLOCK            | MFB-412E-04             | 1  |
| 32  | OIL WAY BLOCK            | MFB-412E-03             | 1  |

**14.3 Hydraulic pump**

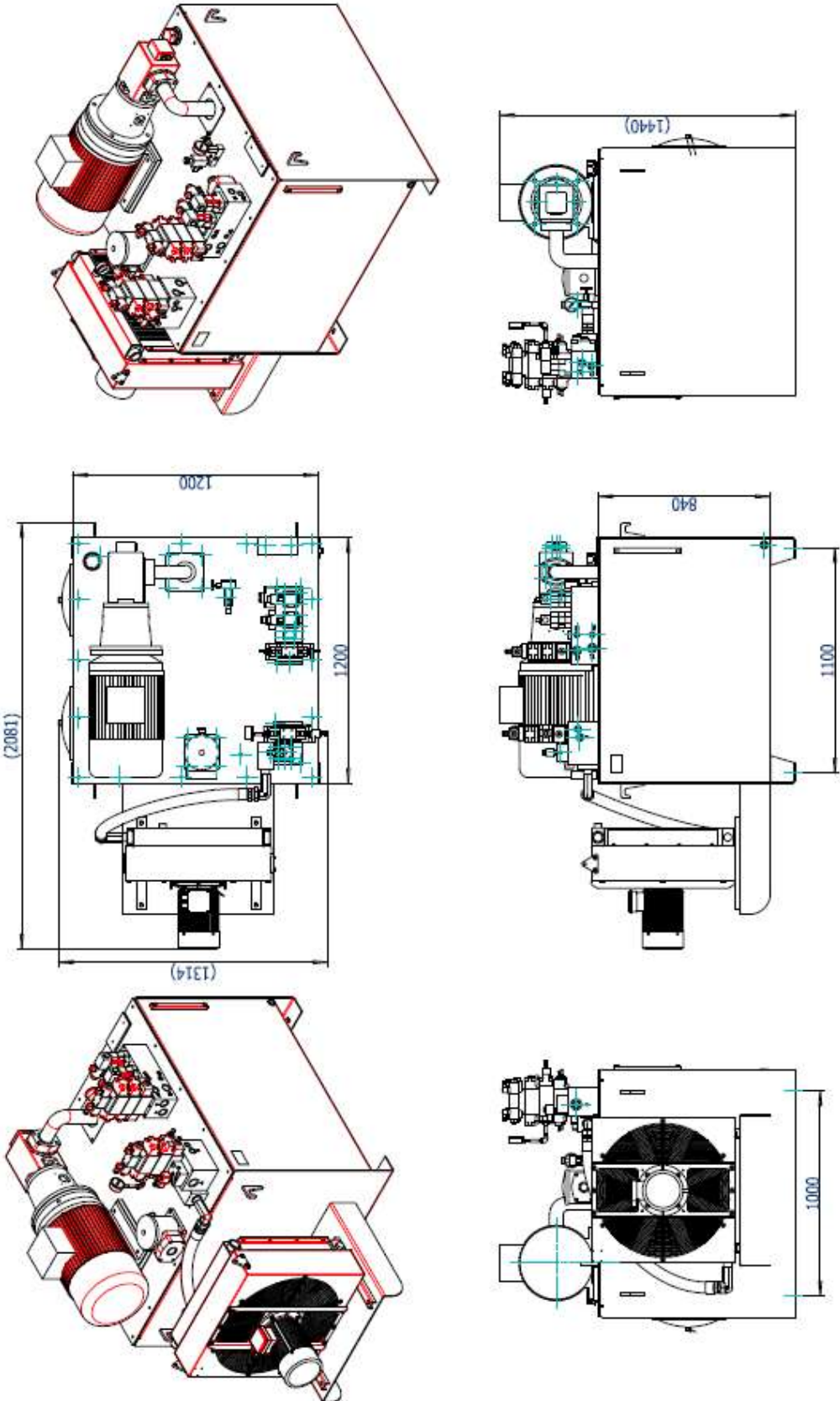



**15 CLARIFICATION FOR PERSONAL TRAINING**

This is to certify that I have attended an in company training for service and operation of the shredder and understand all safety regulations. Further to this I have read and understand the owners' manual.

| <b>City</b> | <b>Date</b> | <b>Printed name</b> | <b>Signature</b> |
|-------------|-------------|---------------------|------------------|
|             |             |                     |                  |
|             |             |                     |                  |
|             |             |                     |                  |
|             |             |                     |                  |
|             |             |                     |                  |
|             |             |                     |                  |
|             |             |                     |                  |
|             |             |                     |                  |
|             |             |                     |                  |



---

## **16 ELECTRICAL CONNECTION**

The machine should be wired by a qualified electrician.

Please refer to the wiring diagram.



---

## **17 DIMENSIONS OF STANDARD MACHINE**

**Please refer to the machines “layout” delivered**



---

**18      ADDITION**

Documentation Main Drive Shredder  
(PART B)  
Documentation SEW gearbox  
Electrical diagram  
Delivery documentation

**ATTENTION:**

**The wiring schematics are located in the control panel in the event that the control panel is a part of the delivery**